

1.

2.

3.

—

4.

5.

6.

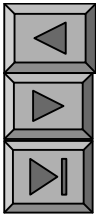

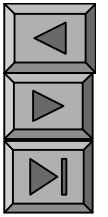

+

10 11 12

9 1

1. Z

(1)

$$\dot{U} \quad U \quad \underline{u} \quad \dot{i} \quad I \quad \underline{i}$$

$$Z \stackrel{\text{def}}{=} \frac{\dot{U}}{\dot{i}} \quad \frac{U}{I} \quad \underline{u \quad i} \quad |Z| \quad \underline{z}$$

$$|Z| \quad \frac{U}{I}$$

$z \quad u \quad i$

z

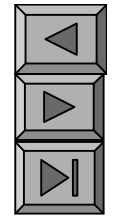
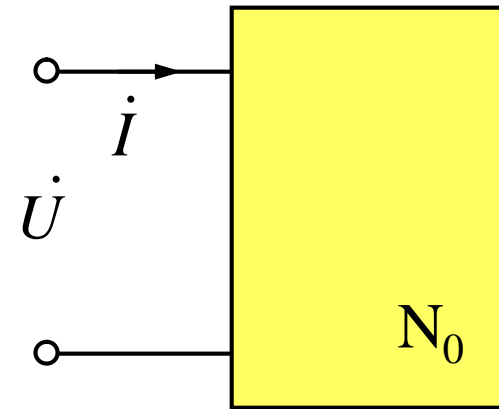

(2)

$$Z = |Z| e^{j\varphi}$$

$$: Z = |Z| \angle \varphi$$

$$Z = |Z| \cos \varphi + j |Z| \sin \varphi$$

$$Z = R + jX$$

$$Z = R + jX$$

$$\begin{cases} R = |Z| \cos \varphi \\ X = |Z| \sin \varphi \end{cases} \begin{cases} |Z| = \sqrt{R^2 + X^2} \\ \varphi = \arctg \frac{X}{R} \end{cases}$$

$$|Z| = \sqrt{R^2 + X^2}$$

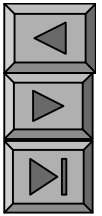
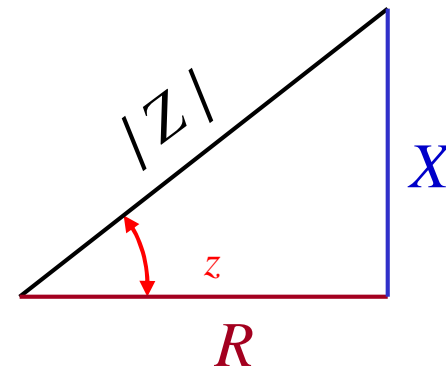
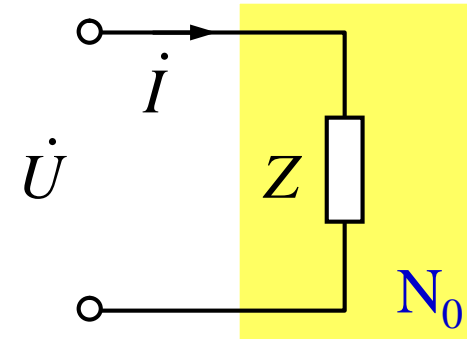

(3)

$$\begin{aligned} Z &= \frac{\dot{U}}{\dot{I}} = R \\ Z &= \frac{\dot{U}}{\dot{I}} = j\omega L = jX_L \\ X_L &= \omega L = 2\pi fL \\ Z &= \frac{\dot{U}}{\dot{I}} = \frac{1}{j\omega C} = -j\frac{1}{\omega C} = -jX_C \\ X_C &= \frac{1}{\omega C} = \frac{1}{2\pi fC} \end{aligned}$$

$X_C = (1/f) !$

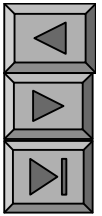
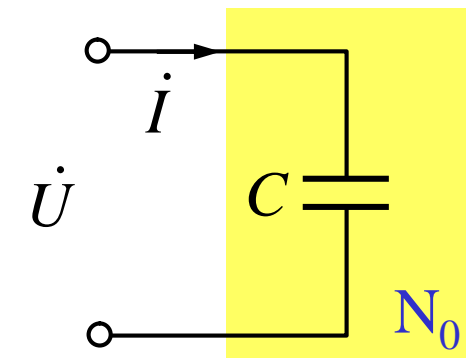
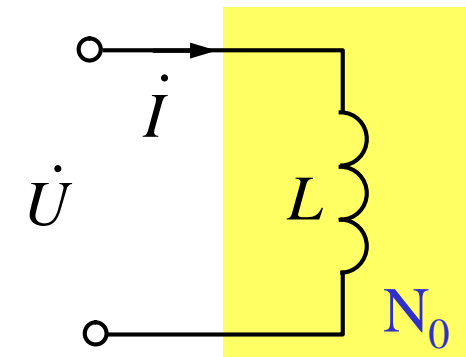
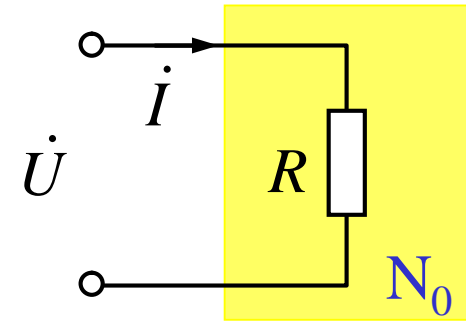

(4)RLC

KVL VCR

$$\dot{U} = R\dot{i} + j\omega L\dot{i} + j\omega^{-1}C\dot{i}$$

$$\left[R \quad j\omega L \quad j\omega^{-1}C \right] \dot{i} = [R \quad j(X_L \quad X_C)] \dot{i}$$

$$R \quad jX \quad Z\dot{i}$$

$$Z = \frac{\dot{U}}{\dot{i}} = R + jX \quad |Z| \angle \varphi_z \quad \text{ö}' - \tilde{n} \quad u$$

$$X = X \quad L \quad \frac{1}{C}$$

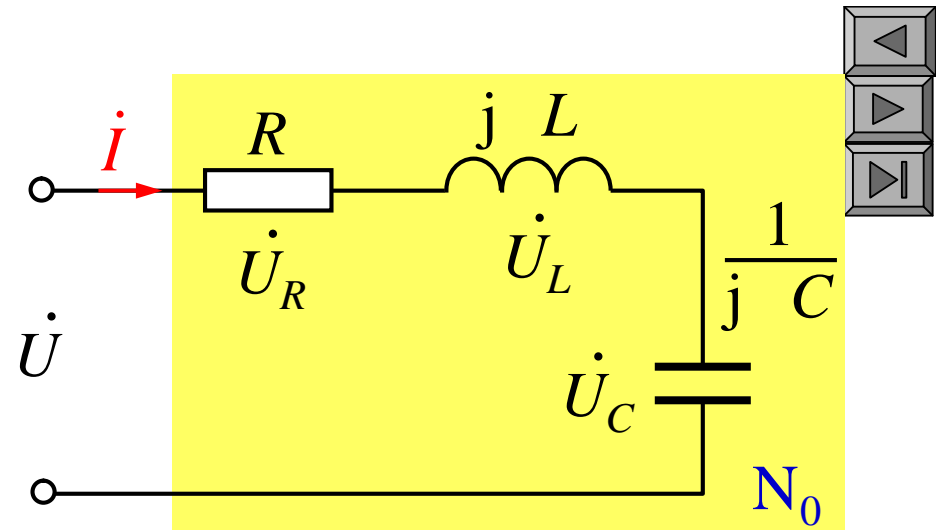

$$Z = \frac{\dot{U}}{\dot{I}} = R + jX \quad |Z| = L_z$$

$$X = X_L - X_C = L - \frac{1}{C}$$

$$z = \arctg \frac{X}{R}$$

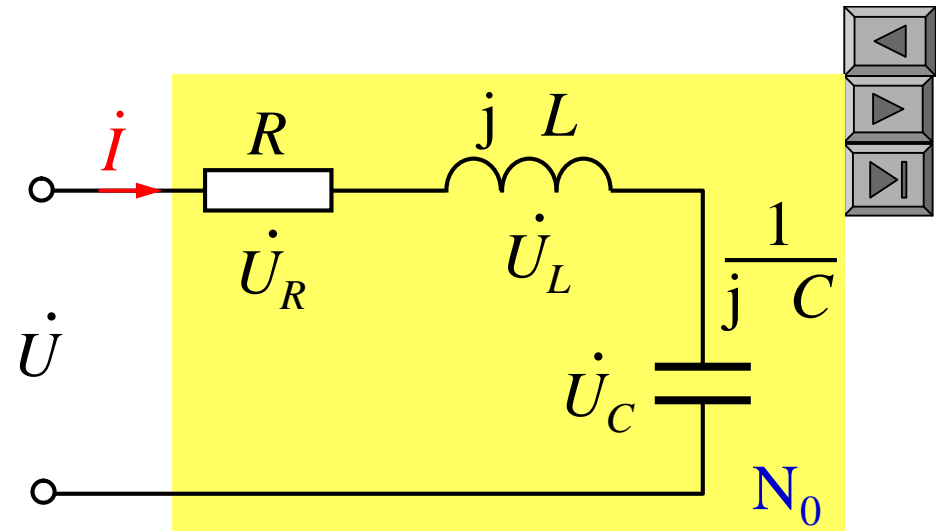

$$L - \frac{1}{C} = X$$

$$z = \arctg \frac{X}{R}$$

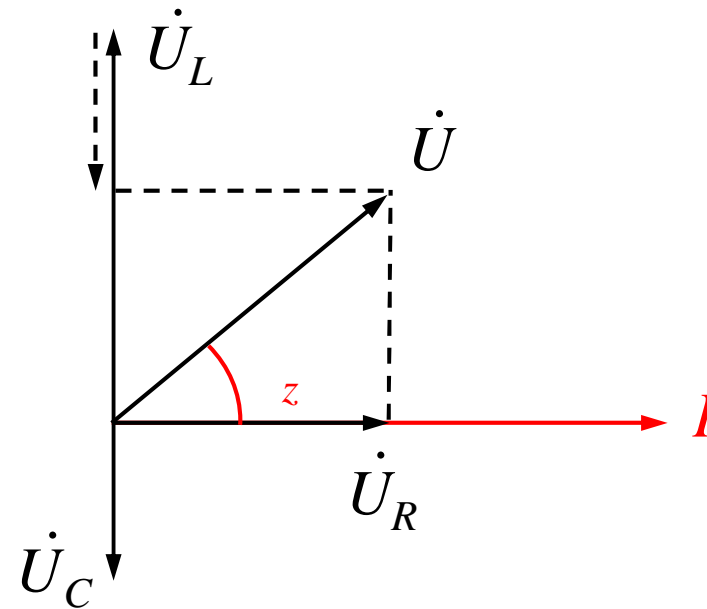

$$Z = \frac{\dot{U}}{\dot{I}} = R + j$$

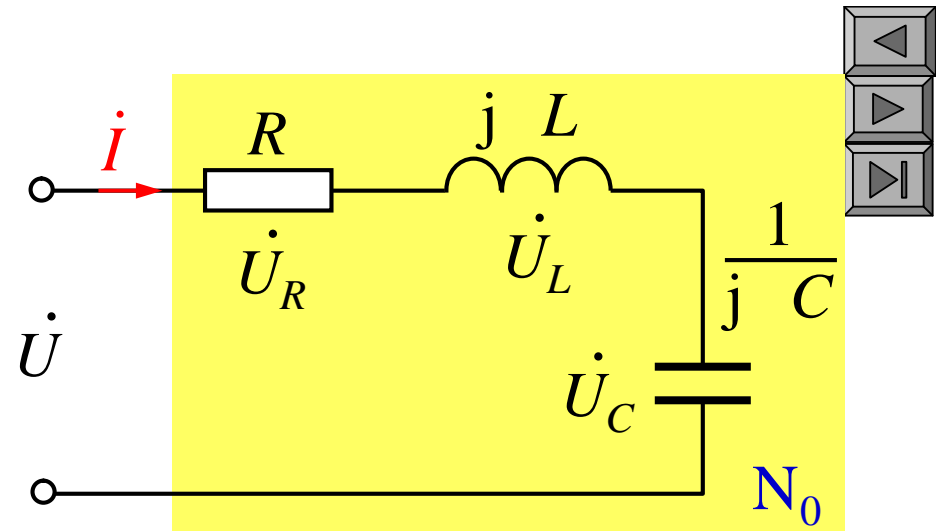

$$Z = R + j\omega L + \frac{1}{j\omega C}$$

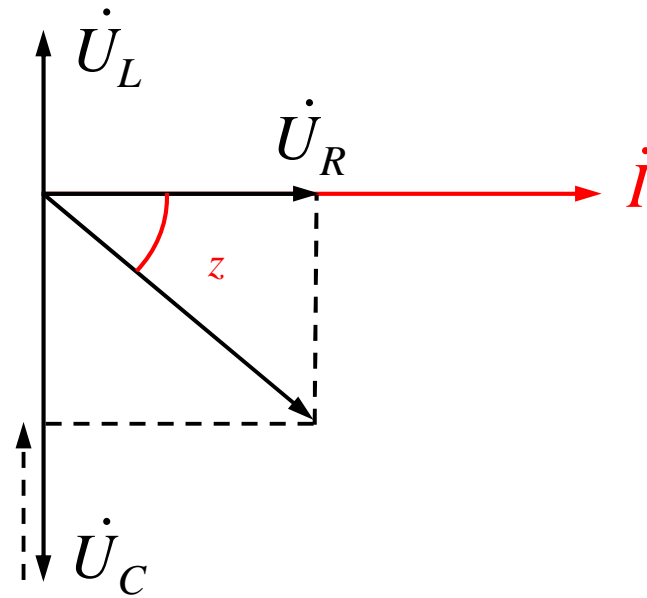

$$Z = \frac{\dot{U}}{\dot{I}} = R + jX \quad |Z| = L_z$$

$$X = X_L - X_C = L - \frac{1}{C}$$

$$\varphi_z = \arctg \frac{X}{R}$$

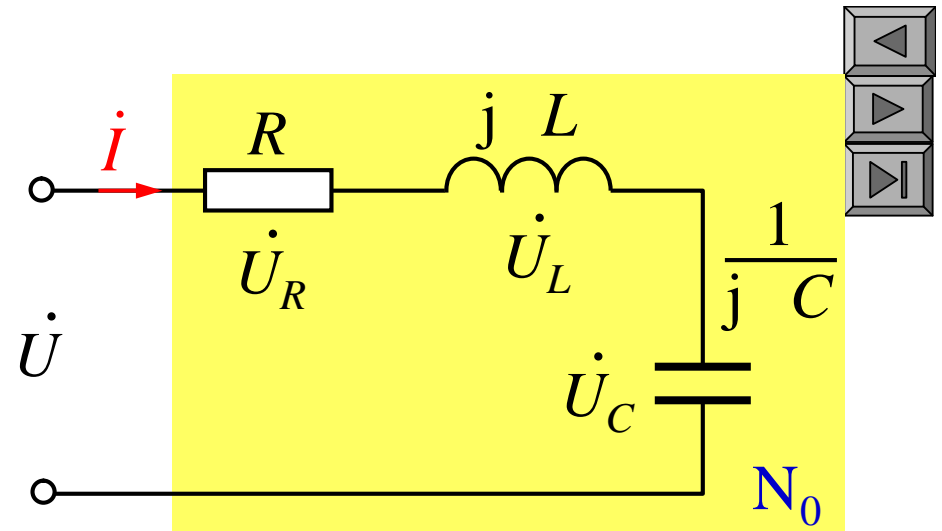

$$X = L - \frac{1}{C}$$

$$\varphi_z = 0$$

$$Z$$

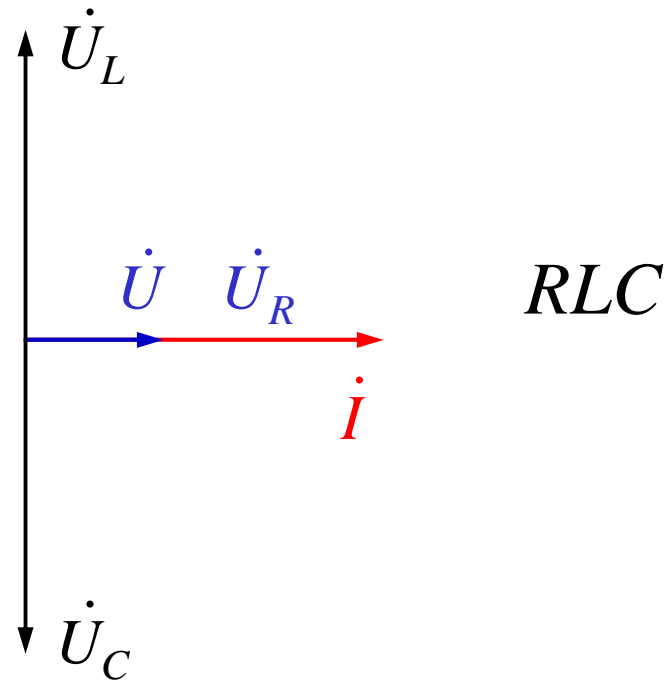

$$Z = \frac{\dot{U}}{\dot{I}} = R + jX \quad |Z| \angle z$$

$$X = X_L - X_C = L\omega - \frac{1}{C\omega}$$

$$z = \arctg \frac{X}{R}$$

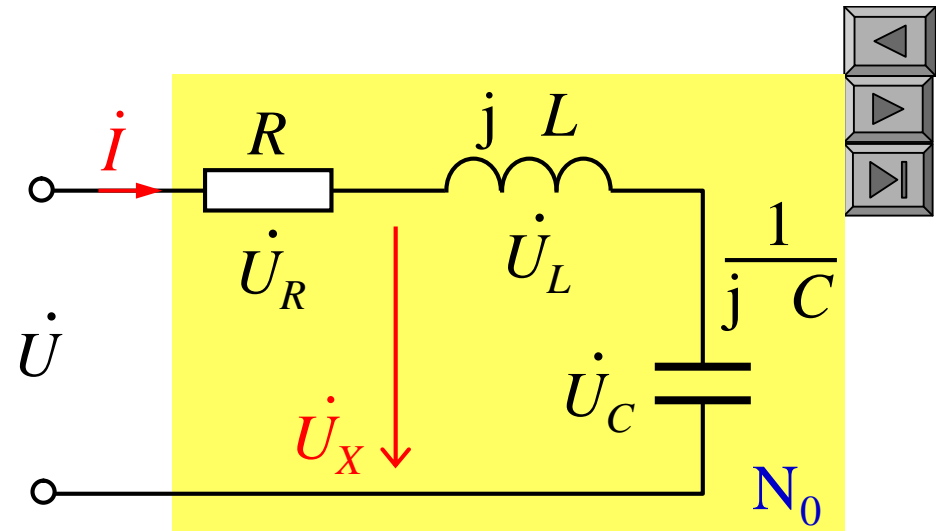

$$R > 0 \quad X > 0 \quad Z$$

$$R > 0 \quad X < 0 \quad Z$$

RLC

$$U_X = U$$

$$U = \sqrt{U_R^2 + U_X^2}$$

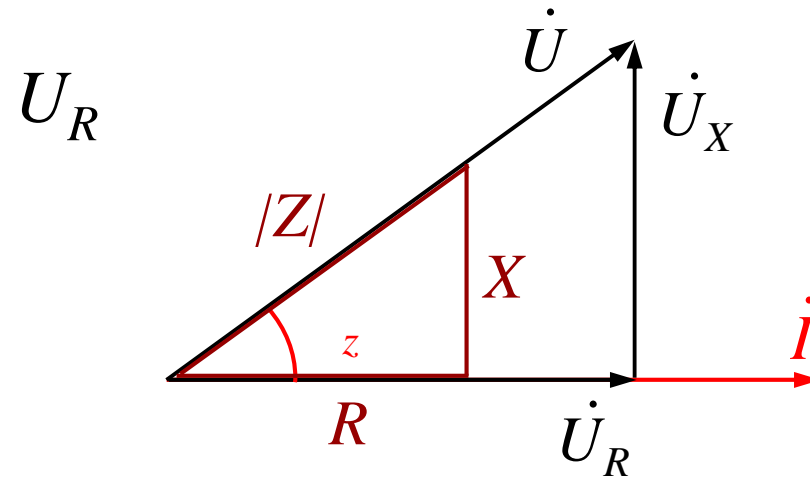

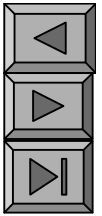

2. Y

(1) Z Y Y $\frac{1}{Z}$

$$Y = \frac{\dot{I}}{\dot{U}} = \frac{I}{U} \angle_{i \ u} |Y| \angle_Y \quad [\quad S]$$

$$|Y| = \frac{I}{U}$$

Y $i \ u$

$Y = G + jB$

G

B

$G, B = |Y| \sin \varphi_Y$

$$\left. \begin{aligned} G &= |Y| \cos \varphi_Y \\ B &= |Y| \sin \varphi_Y \end{aligned} \right\}$$

$$\left. \begin{aligned} |Y| &= \sqrt{G^2 + B^2} \\ \varphi_Y &= \arctg \frac{B}{G} \end{aligned} \right\}$$

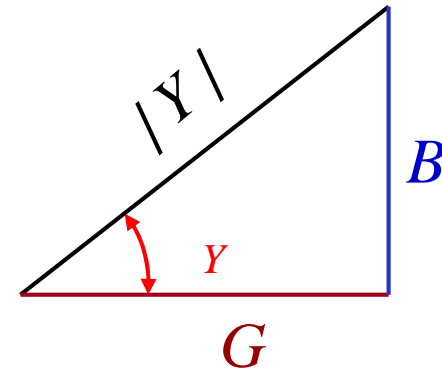

(2) $R \quad L \quad C$

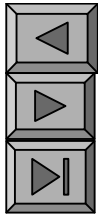
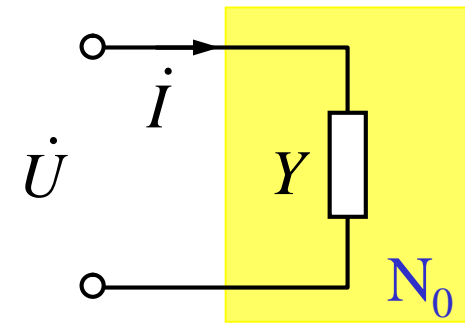

$$Y \quad \frac{\dot{I}}{\dot{U}} \quad \frac{1}{R} \quad G \quad \text{---}$$

$$Y \quad \frac{\dot{I}}{\dot{U}} \quad \frac{1}{jL} \quad jB_L$$

$$B_L \quad \frac{1}{L} \quad \text{---}$$

$$Y \quad \frac{\dot{I}}{\dot{U}} \quad jC \quad jB_C \quad Y$$

$$B_C \quad C \quad \text{---}$$

(3) RLC

VCR KCL

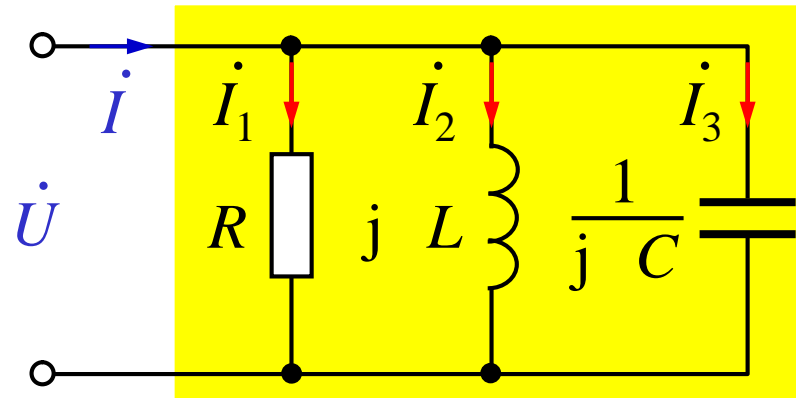

$$\dot{I} = G\dot{U} + \frac{1}{jL}\dot{U} + jC\dot{U}$$

$$\left[G \quad j\frac{1}{L} \quad jC \right] \dot{U} = \left[G \quad j(B_L \quad B_C) \right] \dot{U}$$

$$G \quad jB \quad Y\dot{U}$$

$$Y = \frac{\dot{I}}{\dot{U}} = G + jB \quad |Y| \angle \varphi_Y$$

$$B = B_L \quad B_C \quad \frac{1}{L} \quad C$$

$$|Y| = \sqrt{G^2 + B^2} \quad \varphi_Y = \arctg \frac{B}{G}$$

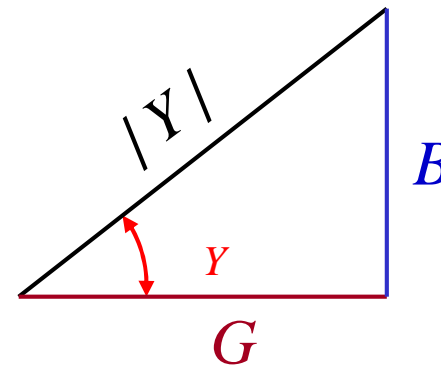

$$Y = \frac{\dot{I}}{\dot{U}} = G + jB \quad |Y| \angle \varphi_Y$$

$$B = B_L + B_C = \frac{1}{L} - \frac{1}{C}$$

$$|Y| = \sqrt{G^2 + B^2} \quad \varphi_Y = \arctg \frac{B}{G}$$

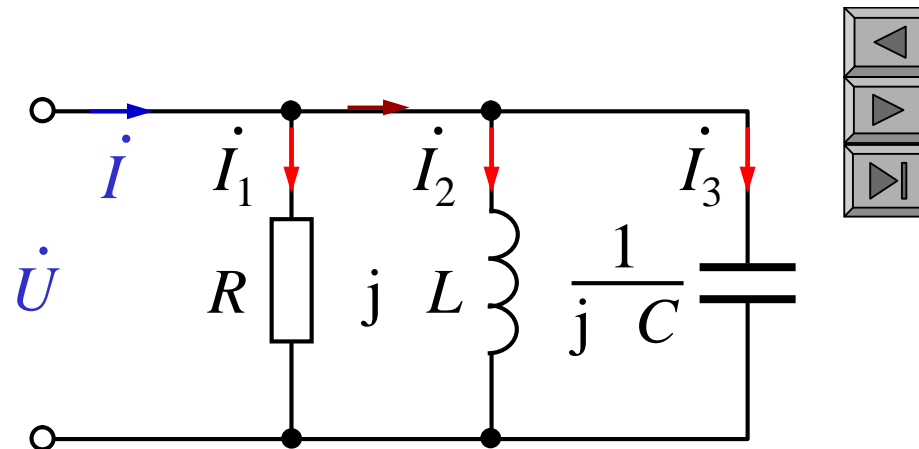

RLC

$$B = 0 \quad Y = 0, \quad Y$$

$$B = 0 \quad Y = 0, \quad Y$$

$$B = 0 \quad Y = 0, \quad Y$$

$$G = 0, \quad B = 0, \quad Y$$

$$G = 0, \quad B = 0, \quad Y$$

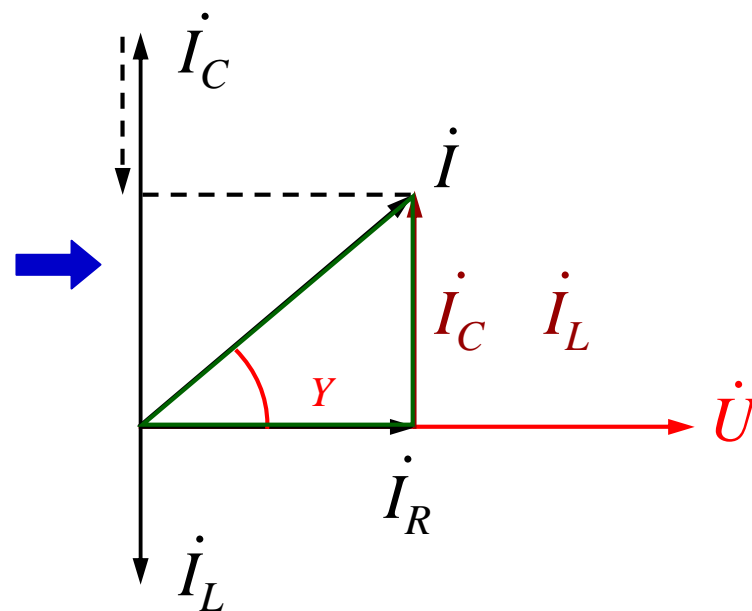

$$Y = \frac{\dot{I}}{\dot{U}} = G + jB \quad |Y| \angle \varphi_Y$$

$$B = B_L + B_C = \frac{1}{L} - C$$

$$|Y| = \sqrt{G^2 + B^2} \quad \varphi_Y = \arctg \frac{B}{G}$$

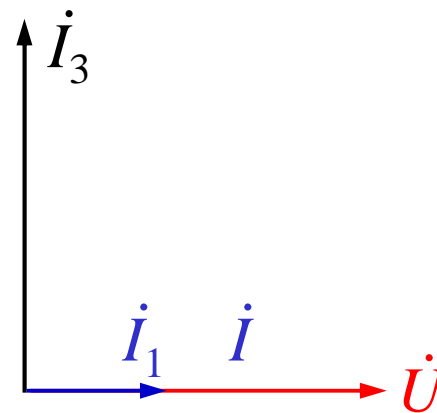
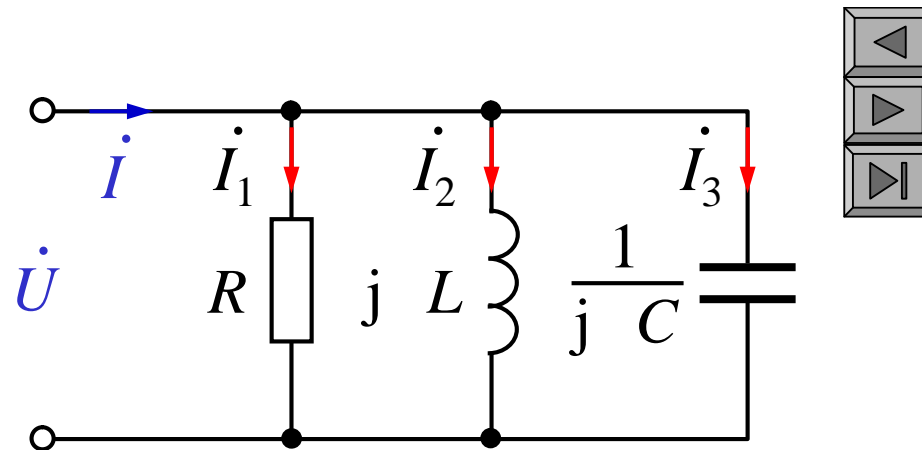

\dot{I}_2

3.

$$N_0 \quad (\quad)$$

$$(\quad) \quad (\quad)$$

$$Z(j\omega) = R(\omega) + jX(\omega)$$

$$Y(j\omega) = G(\omega) + jB(\omega)$$

$$Z(j\omega) Y(j\omega) = 1$$

$$|Z|$$

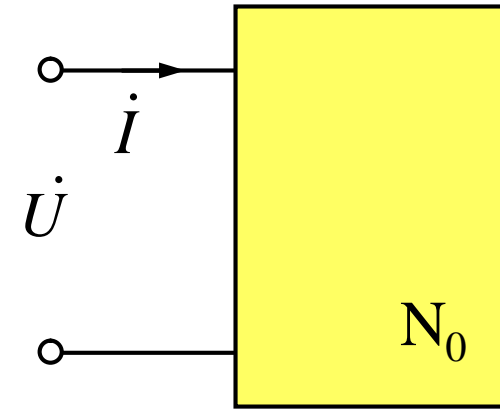

$$Z = 5$$

$$0.2 \text{ S}$$

$$Y = \frac{1}{Z}$$

$$Y = 0.2 \text{ S}$$

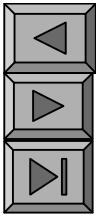

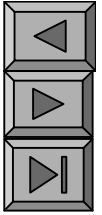

$Z \quad R \quad jX$

$Y \quad G \quad jB$

$$Y = \frac{1}{Z} = \frac{1}{R + jX} = \frac{(R - jX)}{(R + jX)(R - jX)}$$

$$= \frac{R}{R^2 + X^2} - j \frac{X}{R^2 + X^2} = G - jB$$

$$G = \frac{R}{|Z|^2} \quad B = \frac{X}{|Z|^2}$$

$Y \quad G \quad jB$

$Z \quad R \quad jX$

$$R = \frac{G}{|Y|^2} \quad X = \frac{B}{|Y|^2}$$

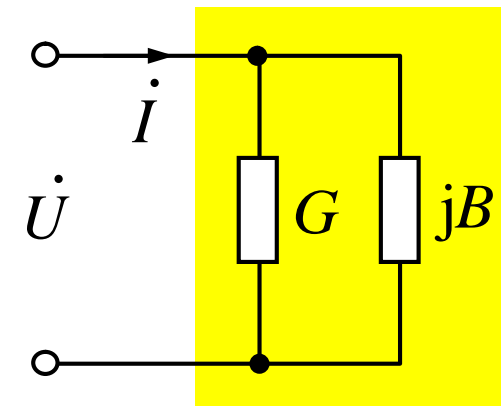
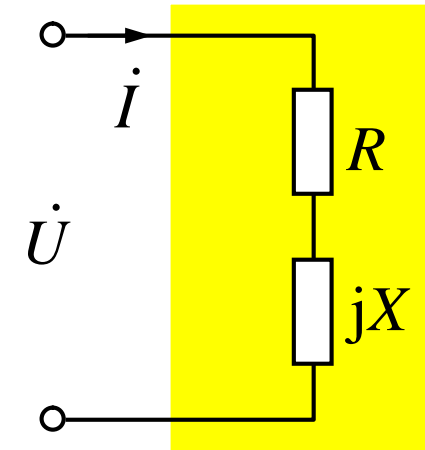



$$\dot{U}_{10}$$

$$\dot{U}_{10}$$

$$\dot{U}_{10} \quad U_{10} \angle 0^\circ \text{ V}$$

$$Z_1$$

$$Y_{10}$$

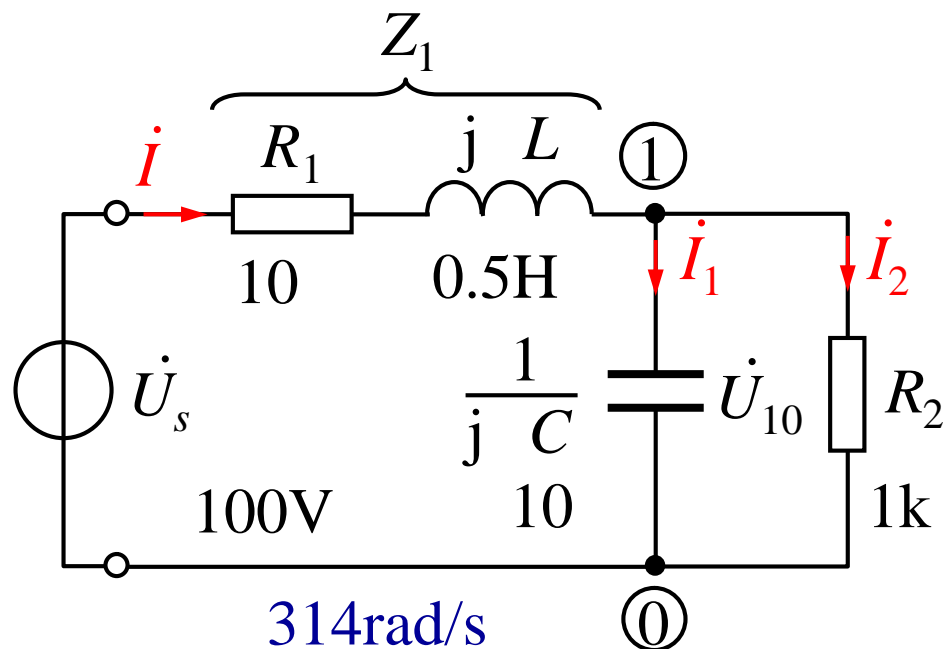

$$Z_1 = 10 + j157$$

$$Y_{10} = \frac{1}{R_2} + j\omega C = 10^{-3} + j3.14 \cdot 10^{-3}$$

$$3.2954 \cdot 10^{-3} \angle 72.33^\circ \text{ S}$$

$$Z_{10} = \frac{1}{Y_{10}} = 303.45 \angle -72.33^\circ = 92.11 - j289.13$$

$$\dot{U}_{10}$$

$$Z_1 \quad 10 \quad j157$$

$$Z_{10} \quad 92.11 \quad j289.13$$

$$303.45 \angle 72.33^\circ$$

$$Z_{eq} \quad Z_1 \quad Z_{10}$$

$$(92.11 \quad 10) \quad j(157 \quad 289.13)$$

$$102.11 \quad j132.13$$

$$166.99 \angle -52.30^\circ$$

$$i \quad \frac{\dot{U}_s}{Z_{eq}} = \frac{100}{166.99 \angle -52.30^\circ}$$

$$0.6 \angle 52.30^\circ \text{ A}$$

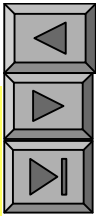
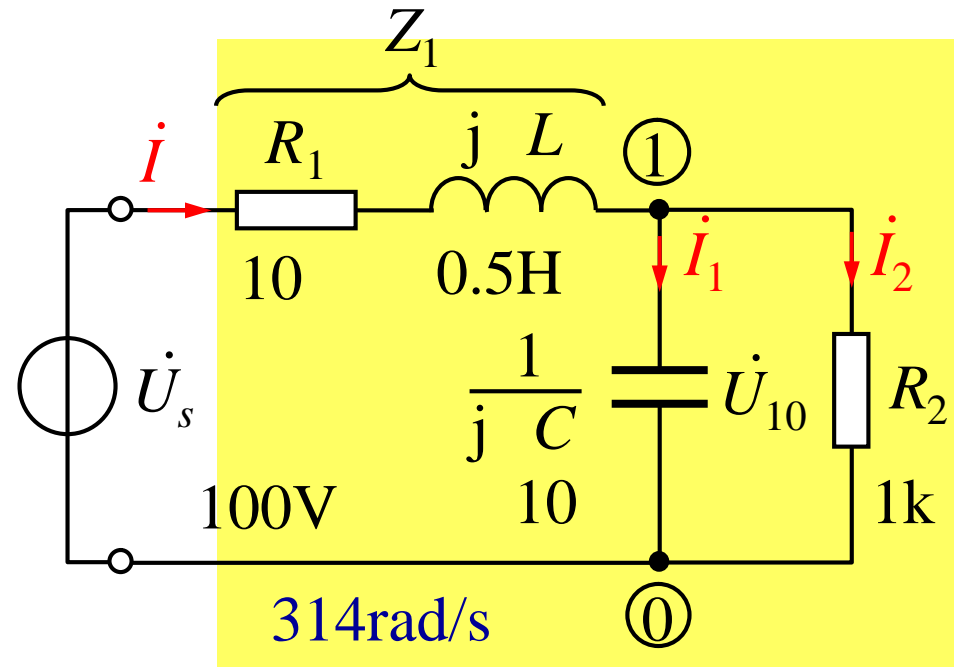

$$\dot{U}_{10}$$

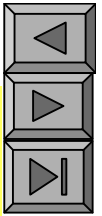
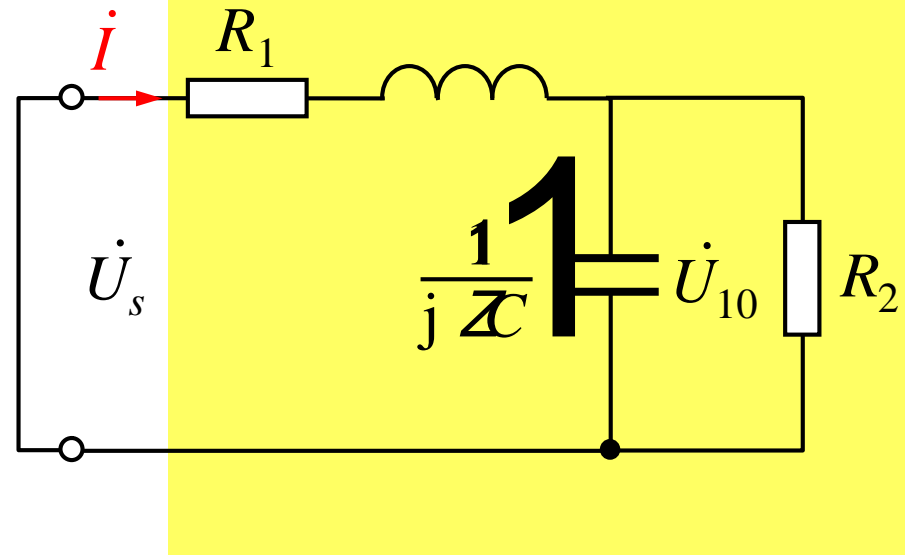

$$\dot{U}_{10} = Z_{10} \dot{I} = 303.45 \angle 72.33^\circ \cdot 0.6 \angle 52.30^\circ$$

$$= 182.07 \angle -20.03^\circ \text{ V}$$

$$\dot{I}_1 = j\omega C \dot{U}_{10} = 182.07 \cdot 0.00314 \angle 90^\circ - 20.03^\circ \text{ A}$$

$$= 0.57 \angle 69.97^\circ \text{ A}$$

$$\dot{I}_2 = \frac{\dot{U}_{10}}{R_2} = 0.182 \angle -20.03^\circ \text{ A}$$

9 2

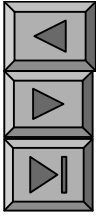

“

”

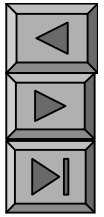

VCR

KCL

VCR

KVL

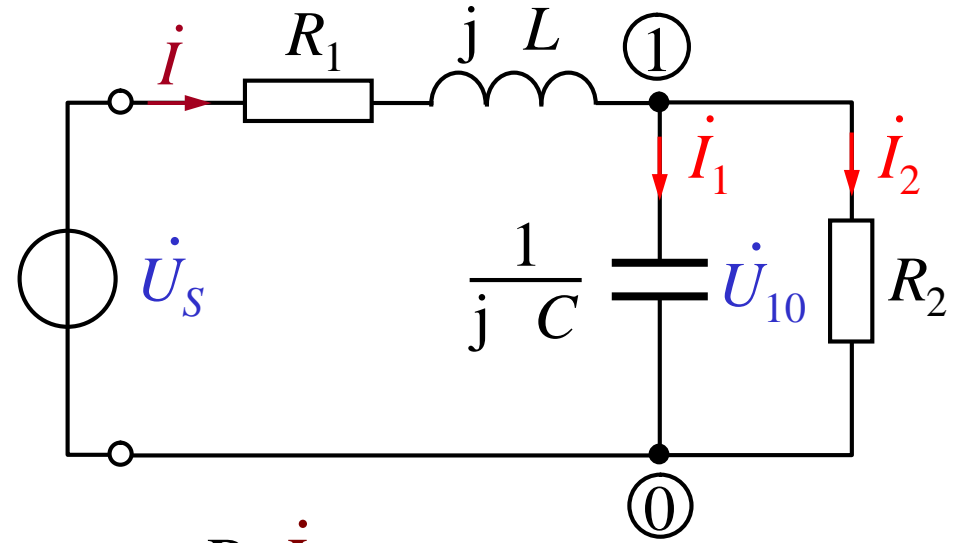
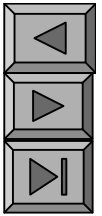

$$\dot{U}_{10} \xrightarrow{\text{VCR}} \begin{Bmatrix} \dot{I}_1 \\ \dot{I}_2 \end{Bmatrix} \xrightarrow{\text{KCL}} \dot{i} \xrightarrow{\text{VCR}} \begin{Bmatrix} R_1 \dot{I} \\ j L \dot{I} \end{Bmatrix} \xrightarrow{\dot{U}_{10} \text{ KVL}} \dot{U}_s$$

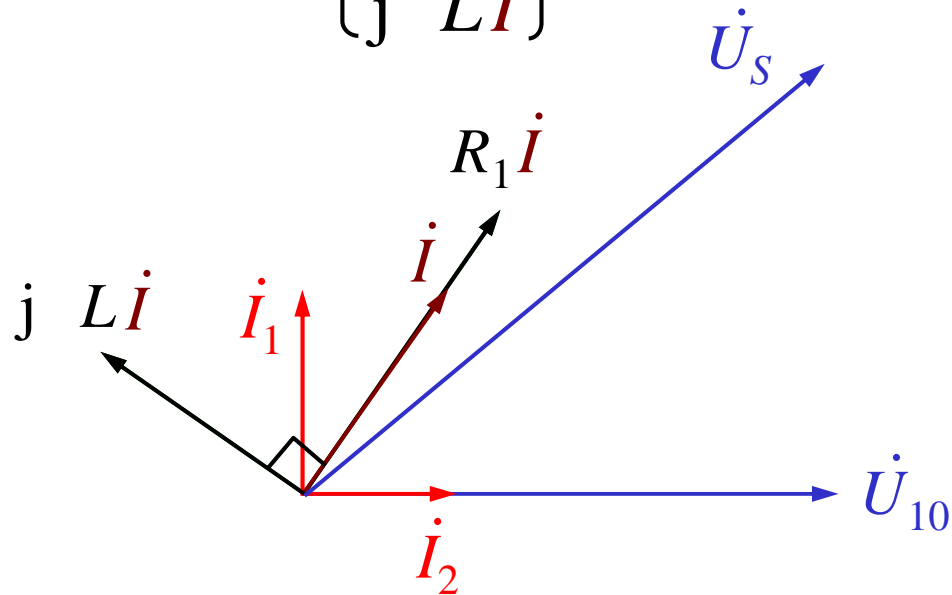

$$\dot{U} = \dot{I}R + \dot{I}X_C + \dot{I}X_L$$

$$\dot{U}_{ab}$$

$$\dot{I}_1 \dot{U}_{ab} \cos 90^\circ$$

$$\dot{I}_2 \dot{U}_{ab}$$

$$\text{KCL } \dot{I} = \dot{I}_1 + \dot{I}_2$$

$$I = \sqrt{I_1^2 + I_2^2} = 14.14 \text{ A}$$

$$jX_L \dot{I} \text{ lags } \dot{I} \text{ by } 90^\circ$$

$$\text{KVL } \dot{U} = jX_L \dot{I} + \dot{U}_{ab}$$

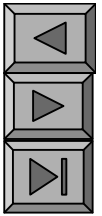
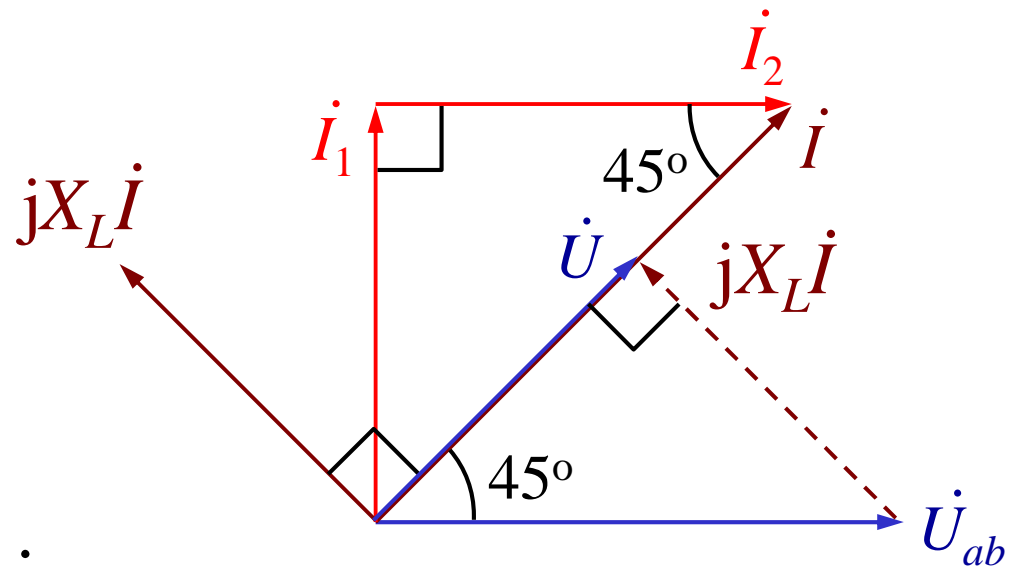
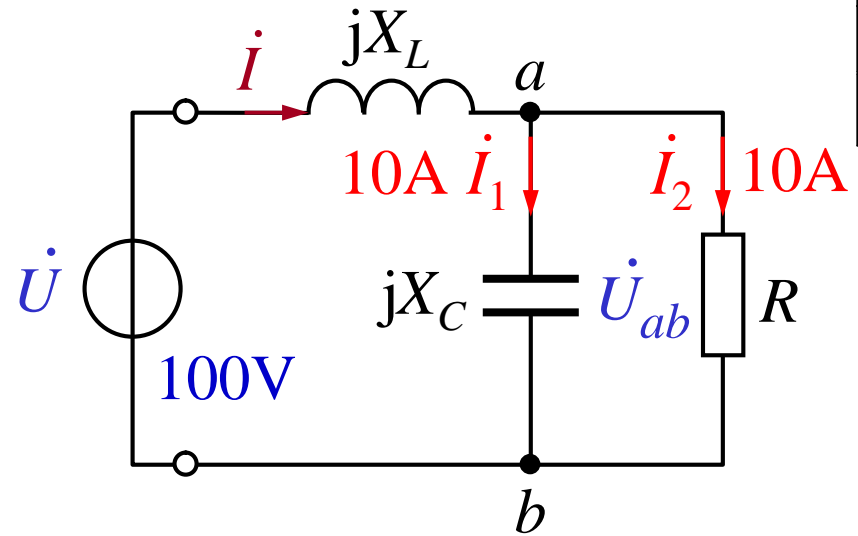

$$I \quad R \quad X_C \quad X_L$$

$$X_L I \quad U \quad 100V$$

$$X_L \quad \frac{U}{I} \quad \frac{100}{14.14} \quad 7.07$$

$$U_{ab} \quad \sqrt{2} U \quad 141.4V$$

$$R \quad \frac{U_{ab}}{I_2} \quad 14.14$$

$$X_C \quad \frac{U_{ab}}{I_1} \quad 14.14$$

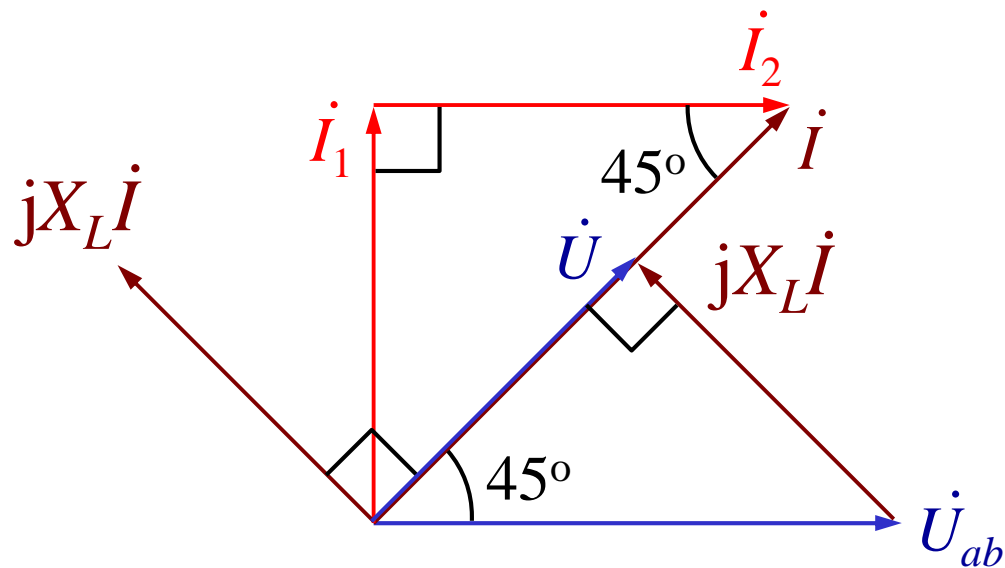
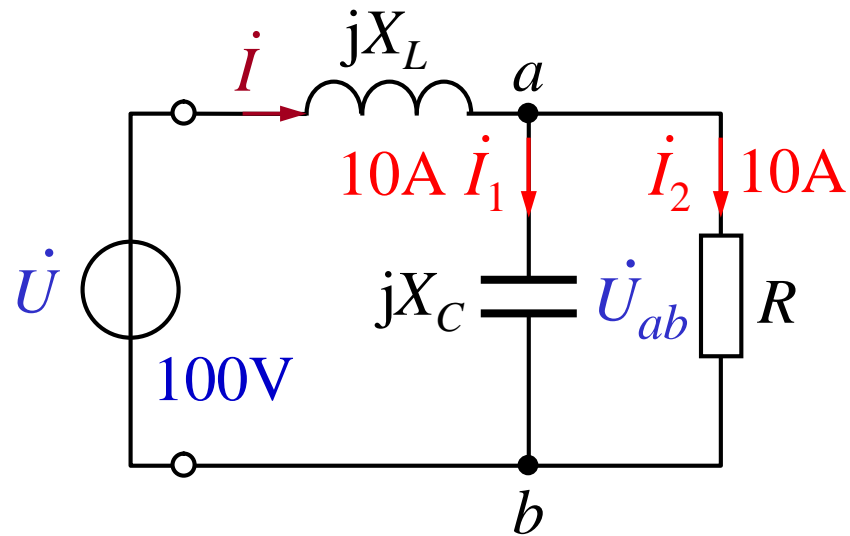

$L \quad C$

$I \quad 14.14 \text{ A}$

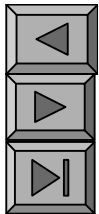

$$\begin{matrix} \dot{U} & \dot{I} \\ I & R & X_C & X_L \end{matrix}$$

$$\dot{U}_{ab}$$

$$\dot{U}_{ab} = U_{ab} \angle 0^\circ \text{ V}$$

$$\dot{I}_1 = j10 \text{ A} \quad \dot{I}_2 = 10 \text{ A}$$

$$\dot{I} = \dot{I}_1 + \dot{I}_2 = (10 + j10) \text{ A}$$

$$14.14 \angle 45^\circ \text{ A}$$

$$\dot{I}_1 \quad \dot{I}_2 \longrightarrow R \quad X_C$$

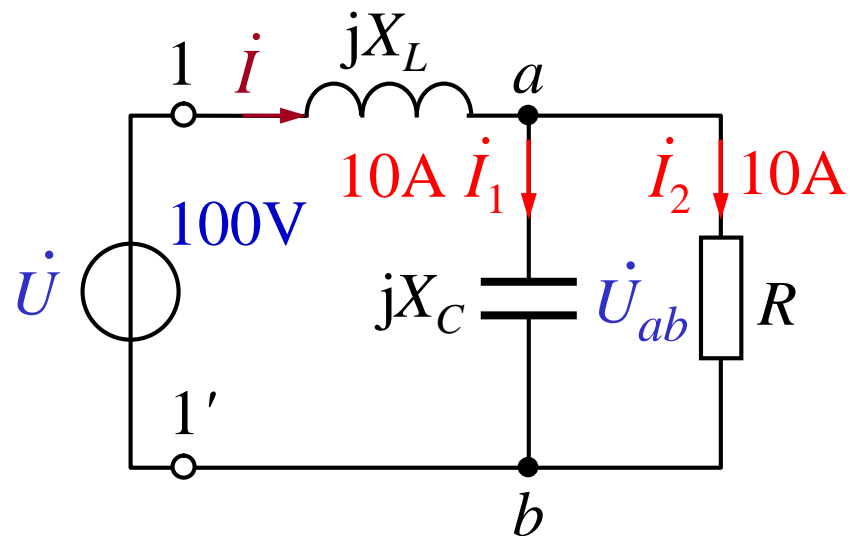

$$Z_{11'} = jX_L + \frac{R(jX_C)}{R + jX_C}$$

$$jX_L + \frac{jX_C}{1-j}$$

$$jX_L + \frac{jX_C(1+j)}{2}$$

$$0.5X_C + j(X_L + 0.5X_C)$$



$$\begin{matrix} \dot{U} & \dot{I} \\ I & R & X_C & X_L \end{matrix}$$

$$Z_{11}' \quad 0.5X_C \quad j(X_L \quad 0.5X_C)$$

$$\dot{U} \quad \dot{I} \quad \rightarrow \quad Z_{11}'$$

$$X_L \quad 0.5X_C \quad 0$$

$$Z_{11}' \quad \frac{\dot{U}}{\dot{I}} \quad \frac{100}{14.14} \quad 7.07 \quad 0.5X_C$$

$$X_C \quad 14.14 \quad R$$

$$X_L \quad 0.5X_C \quad 0 \quad X_L \quad 0.5X_C \quad 7.07$$

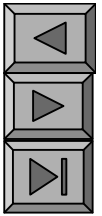
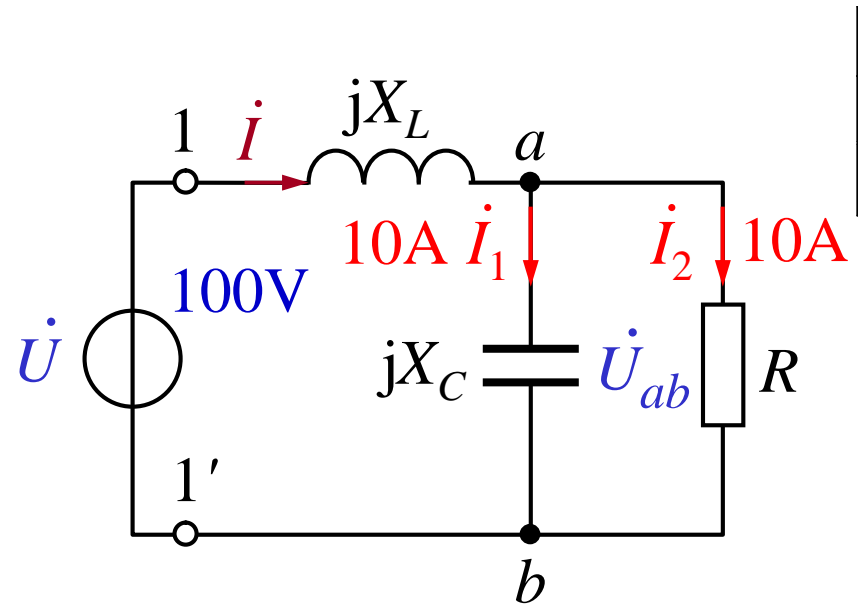

9 3

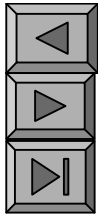

KCL KVL VCR

KCL	$i = 0$	$\dot{i} = 0$
KVL	$u = 0$	$\dot{U} = 0$
VCR	$u = Ri$	$\dot{U} = Z\dot{i}$

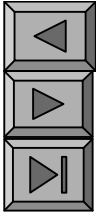

R_{eq}

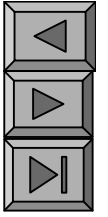

()

p ui

()

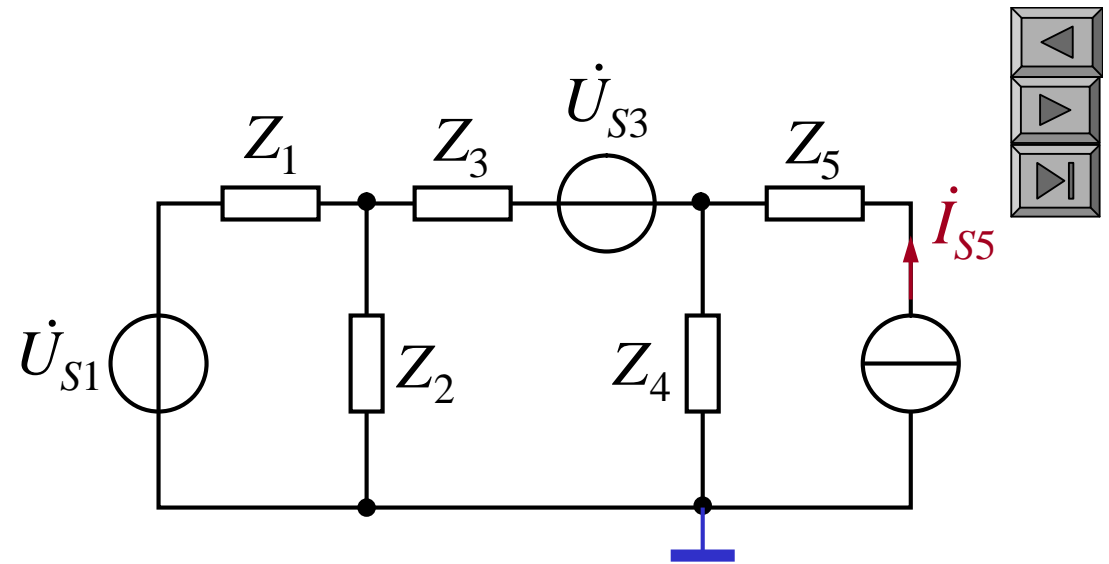

$$(Y_1 \ Y_2 \ Y_3) \cdot$$

2

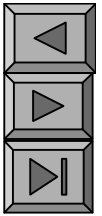
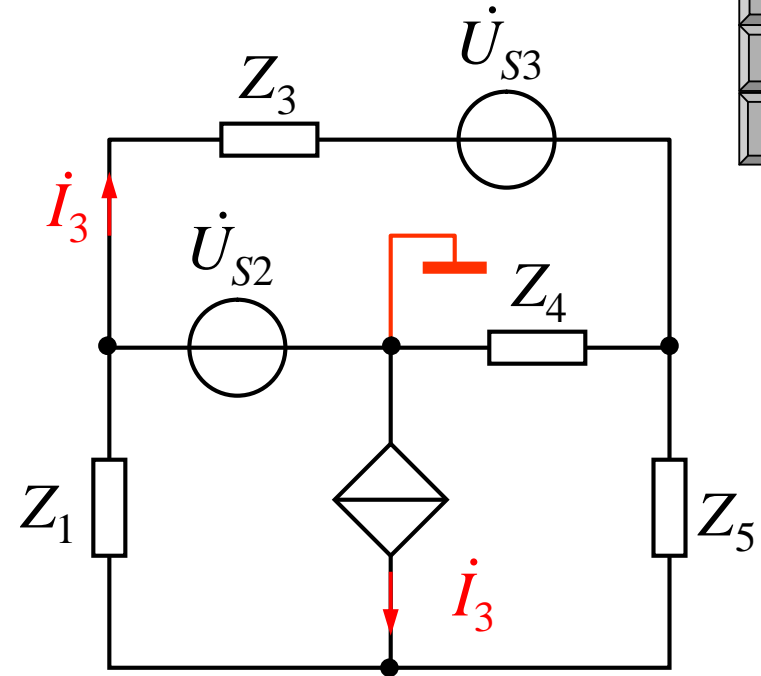

$$\dot{U}_{n1} \quad \dot{U}_{S2}$$

$$Y_3 \dot{U}_{n1} \quad (Y_3 \quad Y_4 \quad Y_5) \dot{U}_{n3} \quad Y_5 \dot{U}_{n4} \quad Y_3 \dot{U}_{S3}$$

$$Y_1 \dot{U}_{n1} \quad Y_5 \dot{U}_{n3} \quad (Y_1 \quad Y_5) \dot{U}_{n4} \quad \dot{I}_3$$

$$\dot{I}_3 = \frac{(\dot{U}_{n1} \quad \dot{U}_{n3})}{Z_3} \dot{U}_{S3} - Y_3 (\dot{U}_{n1} \quad \dot{U}_{n3} \quad \dot{U}_{S3})$$

3

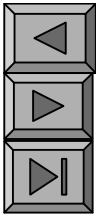
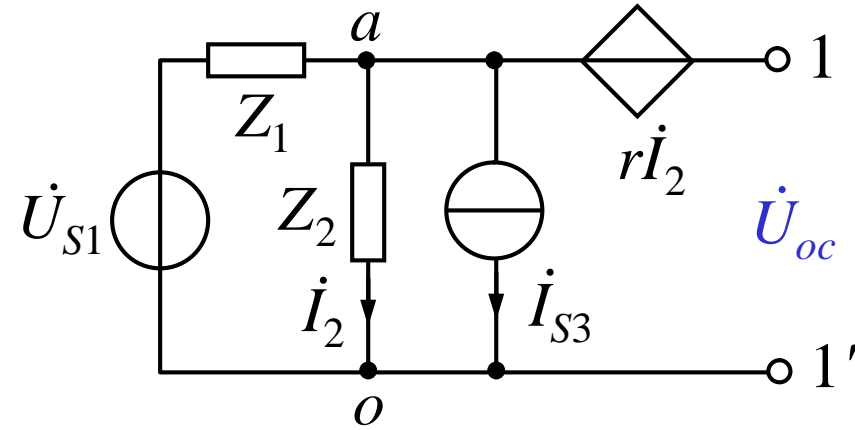

$$\dot{U}_{oc} = r\dot{I}_2 + \dot{U}_{ao}$$

$$\dot{I}_2 = Y_2 \dot{U}_{ao}$$

$$\dot{U}_{oc} = rY_2 \dot{U}_{ao} \quad \dot{U}_{ao} = (1 - rY_2) \dot{U}_{ao}$$

$$\dot{U}_{ao} = \frac{Y_1 \dot{U}_{S1} + \dot{I}_{S3}}{Y_1 + Y_2}$$

$$\dot{U}_{oc} = \frac{(1 - rY_2)(Y_1 \dot{U}_{S1} + \dot{I}_{S3})}{Y_1 + Y_2}$$

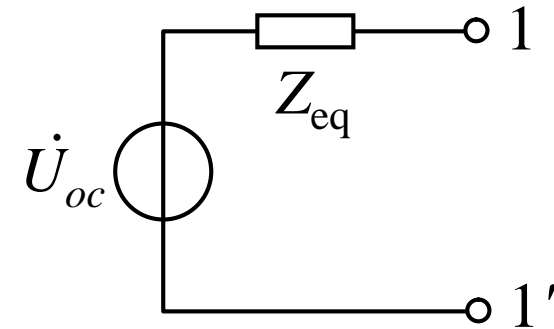

3

$$\dot{U}_{oc} = \frac{(1 - rY_2)(Y_1 \dot{U}_{S1} + \dot{I}_{S3})}{Y_1 + Y_2}$$

$$\dot{I}_2 = \frac{Z_1}{Z_1 + Z_2} \dot{I}$$

$$\dot{I} = \frac{Z_1 + Z_2}{Z_1} \dot{I}_2 = (1 + Y_1 Z_2) \dot{I}_2$$

$$\dot{U} = r \dot{I}_2 + Z_2 \dot{I}_2 = (Z_2 + r) \dot{I}_2$$

$$Z_{eq} = \frac{\dot{U}}{\dot{I}} = \frac{Z_2 + r}{1 + Y_1 Z_2}$$

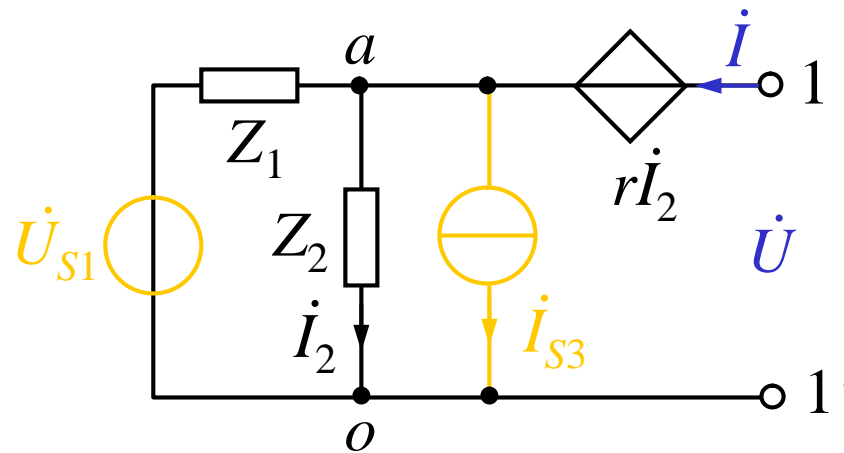
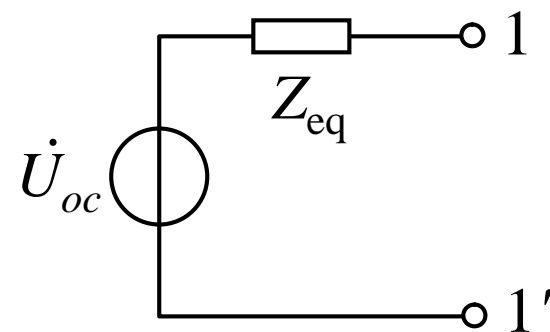
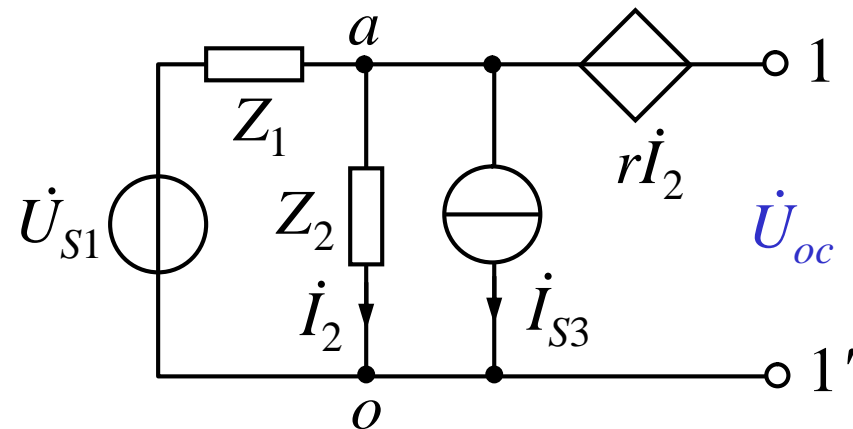



$U_s = 380\text{V}$ $f = 50\text{Hz}$ $C = 80.95\text{ F}$ $I = 2.59\text{A}$

A_1

1

\dot{U}_s

$C \quad I_C$

$i \quad i_1 \quad i_C$

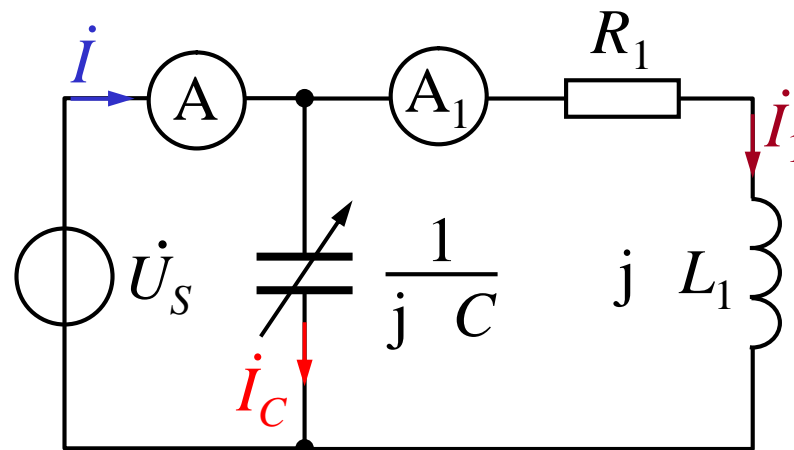

$i_1 \quad i_C \quad \dot{U}_s$

$i \quad \dot{U}_s$

$I_C = 2 f C U_s = 9.66\text{A}$

$I_1 = \sqrt{9.66^2 + 2.59^2} = 10\text{ A}$

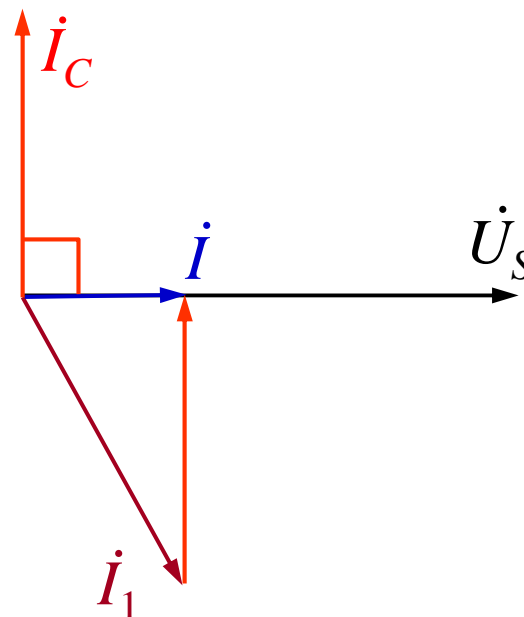

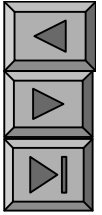

$$4 \quad U_s \quad 380V \quad f \quad 50Hz \quad C$$
$$C \quad 80.95 \quad F \quad A \quad 2.59A$$
$$A_1$$

$$2$$
$$Y \quad j \quad C \quad \frac{R_1}{|Z_1|^2} \quad j \quad \frac{L_1}{|Z_1|^2}$$

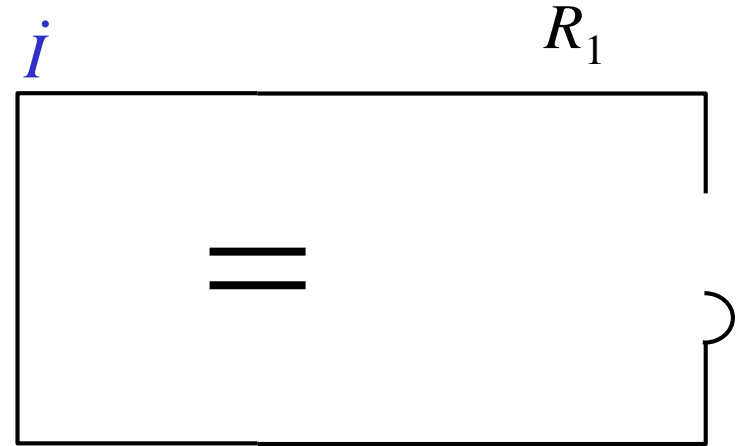

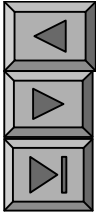

4 U_s 380V f 50Hz C

C 80.95 F

A

2.59A

A_1

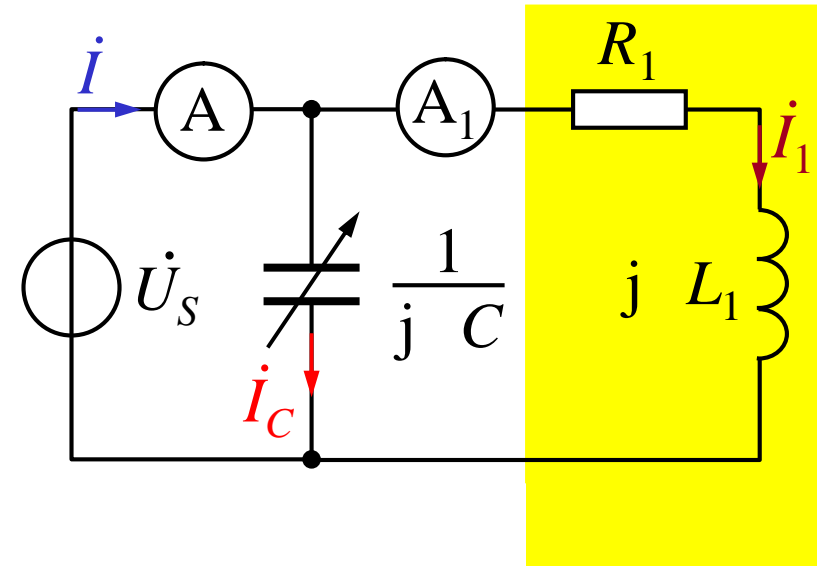

()

$$\dot{I}_1 = 10 \angle 70^\circ \text{ A}$$

$$Z_1 = \frac{\dot{U}_s}{\dot{I}_1} = 38 \angle 70^\circ = 13 + j 35.71$$

$$R_1 = 13 \quad L_1 = \frac{35.71}{\omega} = 113.7 \text{ mH}$$

5 P228 9 5

$$u_S = 200\sqrt{2}\cos(314t) \text{ V}$$

$$I = 2 \text{ A}$$

$$U_{V_1} = 200 \text{ V} \quad U_{V_2} = 200 \text{ V}$$

$R \quad L \quad C$

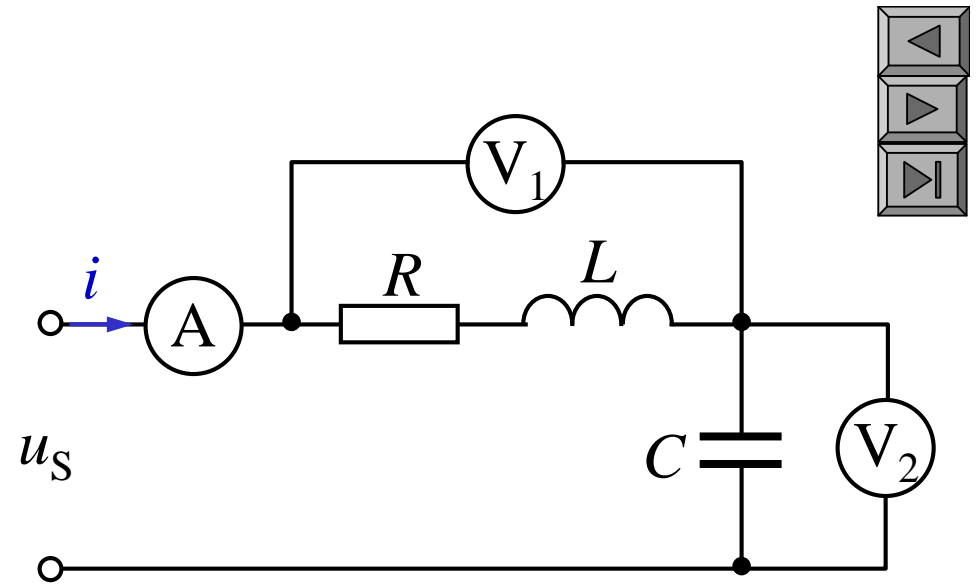

$$i = 2 \angle 0^\circ \text{ A}$$

$$U_2 = j 200 \text{ V}$$

$$U_1 = 200 \angle 30^\circ \text{ V} \quad U_S = 200 \angle -30^\circ \text{ V}$$

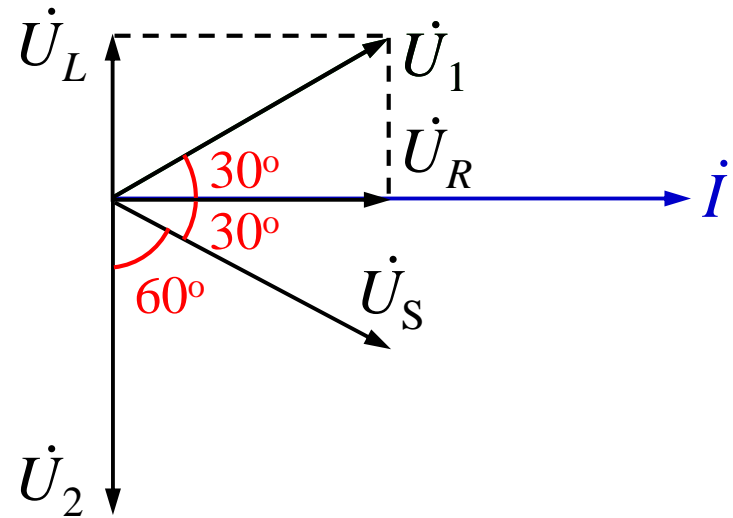

$$\dot{I} \quad \underline{200} \angle 0^\circ \text{ A} \quad \dot{U}_2 \quad j200 \text{ V}$$

$$\dot{U}_1 \quad 200 \underline{200} \angle 30^\circ \text{ V}$$

$$\dot{U}_S \quad 200 \underline{200} \angle 30^\circ \text{ V}$$

$$Z_1 \quad R \quad j \quad L \quad \frac{\dot{U}_1}{\dot{I}} \quad \frac{200 \underline{200} \angle 30^\circ}{2 \underline{200} \angle 0^\circ}$$

$$\underline{86.6} \quad \underline{50} \angle 30^\circ \quad 86.6 \quad j50$$

$$R \quad 86.6 \quad L \quad 50$$

$$L \quad \frac{50}{314} \quad 0.159 \text{ H}$$

$$Z_C \quad \frac{\dot{U}_2}{\dot{I}} \quad \frac{j200}{2} \quad j100$$

$$j \frac{1}{C}$$

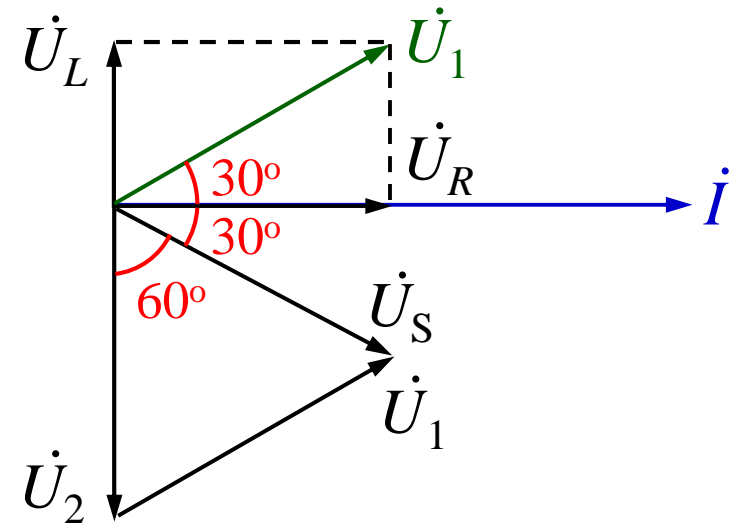
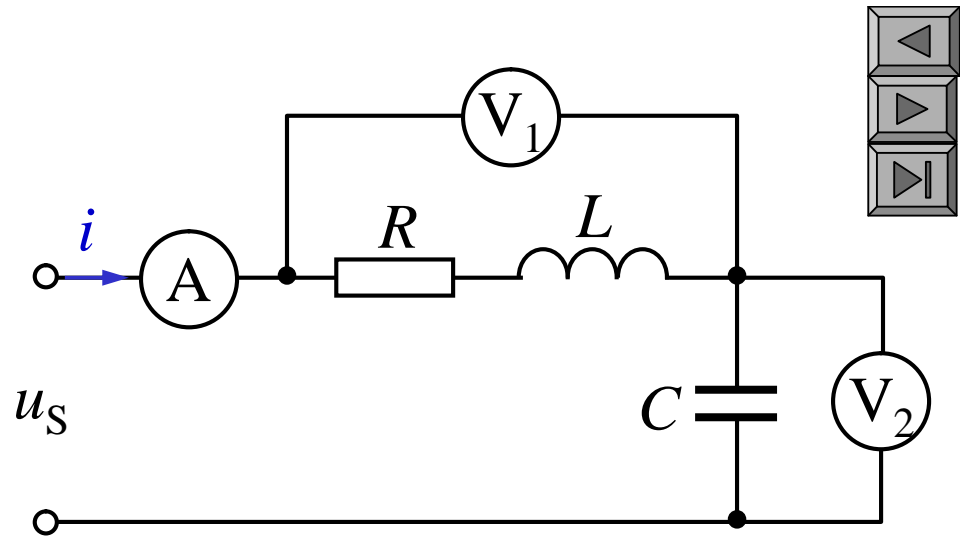

$$C \quad \frac{1}{100} \quad 31.85 \text{ F}$$

$$u_S = 200\sqrt{2}\cos(314t) \text{ V}$$

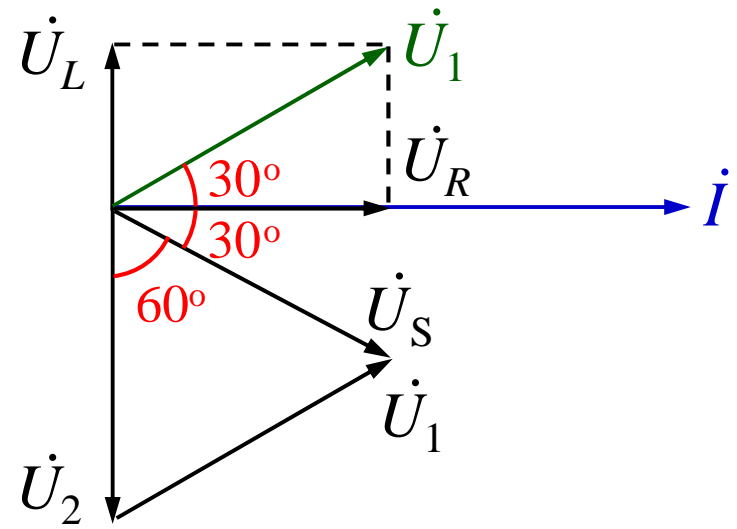
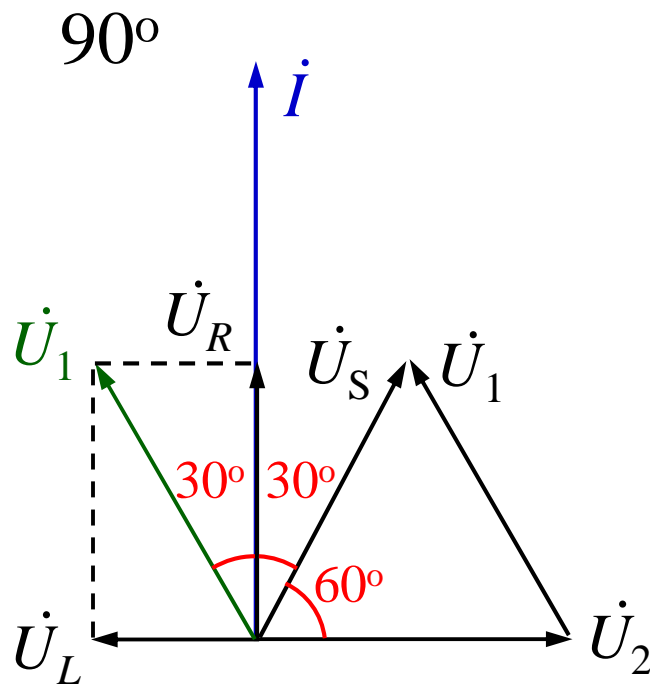
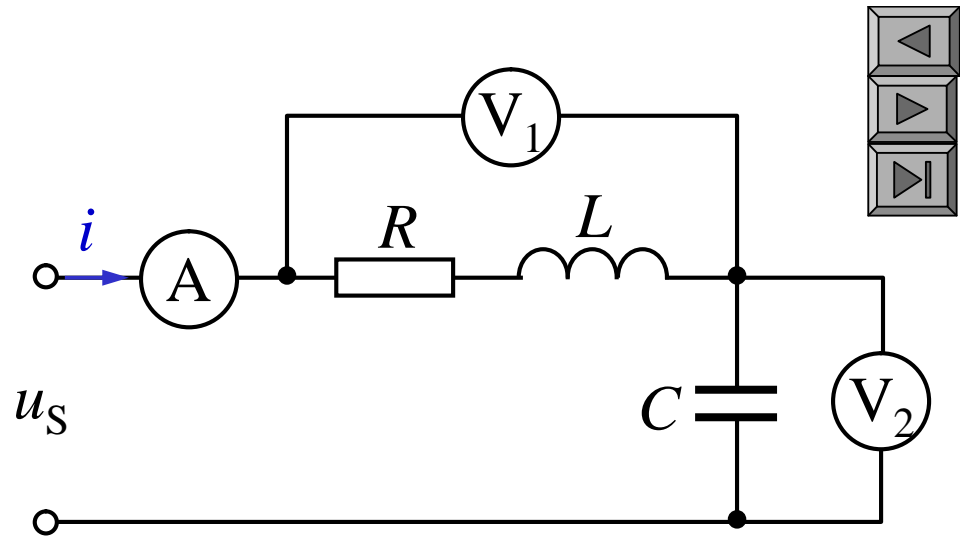

$$u_2 = 200\sqrt{2}\cos 314t \text{ V}$$

6
S
S

$i_L(t)$
 $t = 0$
 i_L u_C

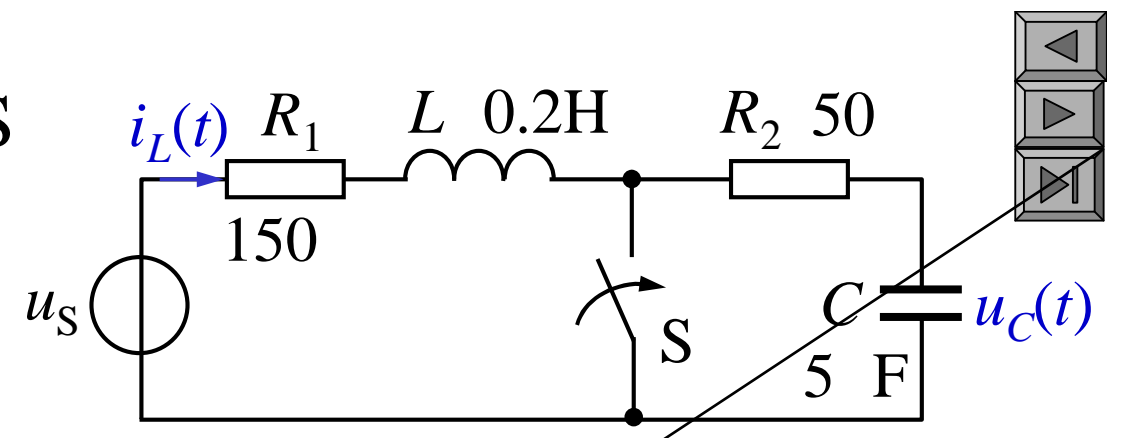

$u_s = 70\sqrt{2} \sin(1000t - 36.9^\circ) \text{ V}$

$t = 0$

$$\dot{I}_L = \frac{\dot{U}_S}{R_1 + R_2 + j\left[L - \frac{1}{C}\right]}$$

$$\frac{150 + 50 + j[0.2 - 0.15]}{150 + 50 + j0.05} \text{ TmJ}$$

0.244.2

$$\dot{I}_L \quad \underline{36.9^\circ} \text{ A}$$

$$\dot{U}_C \quad j200 \dot{I}_L$$

$$70.7 \underline{53.1^\circ} \text{ V}$$

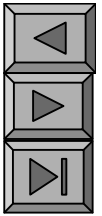
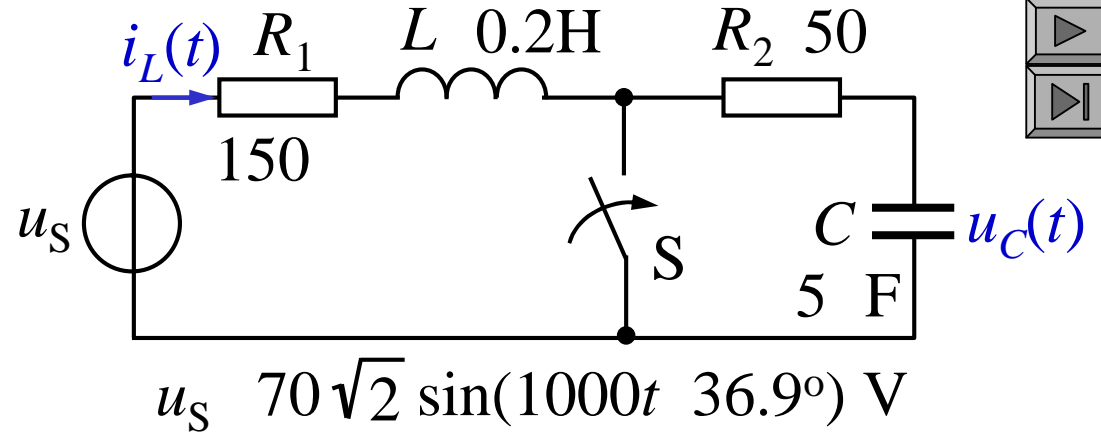

$$i_L \quad \sqrt{2} \sin(t + 36.9^\circ) \text{ A} \quad (t \geq 0)$$

$$i_L(0^+) \quad \sqrt{2} \sin 36.9^\circ \quad 0.3 \text{ A}$$

$$u_C(0^+) \quad \sqrt{2} \sin(53.1^\circ) \quad 80 \text{ V}$$

$$t \geq 0 \quad RC$$

$$\tau = R_2 C = 10^{-4} \text{ s} \quad u_C(\infty) = 0$$

$$u_C(t) = 80 e^{-4000t} \text{ V} \quad (t \geq 0)$$

$$i_L(0^-)$$

$$L R_1$$

$$t = 0$$

RL

S

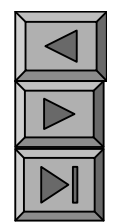
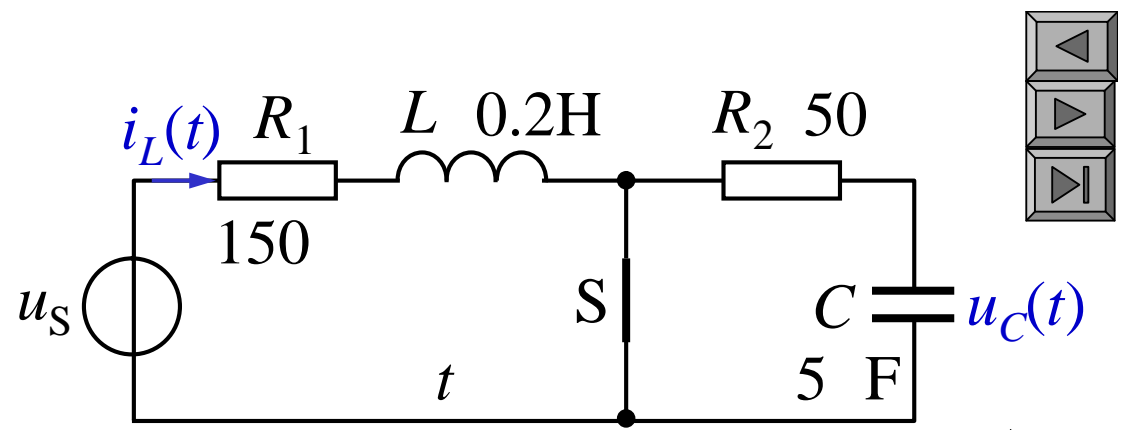

$$f(t) = [f(0^-) + f'(0^-)] e^{-\frac{t}{\tau}}$$

$$\dot{I}_L' = \frac{\dot{U}_S}{R_1 + j\omega L} = \frac{70.7 \angle 36.9^\circ}{150 + j200} \angle 16.23^\circ \text{ A}$$

$$i_L'(0^+) = \sin(16.23^\circ) = .112 \text{ A}$$

$$i_L(0^+) = i_L(0^-)$$

$$i_L'(t) = \sqrt{2} \sin(\omega t + 16.23^\circ) \sin(\omega t + 16.23^\circ) \text{ A}$$

$$i_L(t) = [0.412 e^{-750t} + \sin(\omega t + 16.23^\circ)] \text{ A} \quad (t \geq 0)$$

9 4

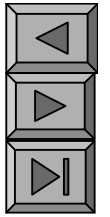

i 0

u *i* *u*



$$p = \underline{UI \cos 2t} - \underline{UI \sin 2t}$$

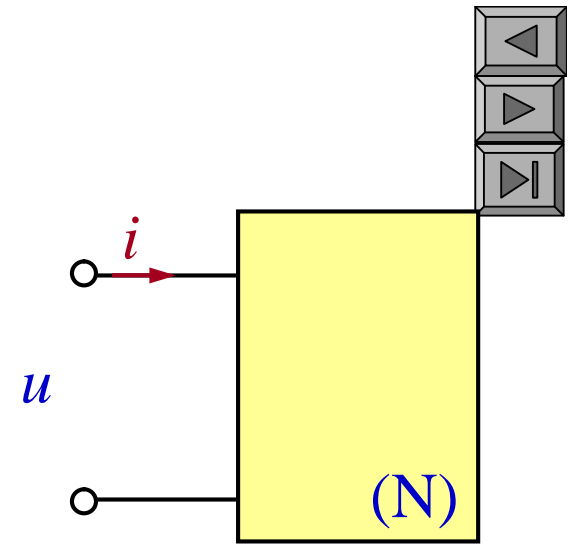

$$p = 0$$

$$p = 0$$

2.

$P \cos (\dots)$

P

P

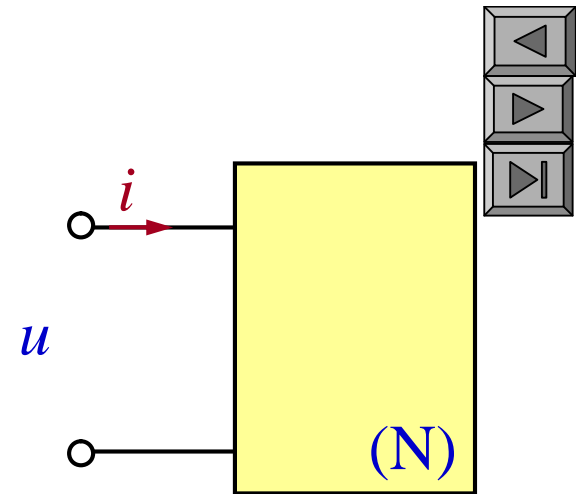

$$P = \frac{1}{T} \int_0^T p \, dt$$

$$P = UI \cos \phi$$

P

\cos

$$0 \leq |\cos \phi| \leq 1 \quad \cos$$

$$P = UI \cos \phi$$

$$P = 0$$

P

3.

Q

$$Q \stackrel{\text{def}}{=} UI \sin$$

Q

Q

()

Q

Var()

S

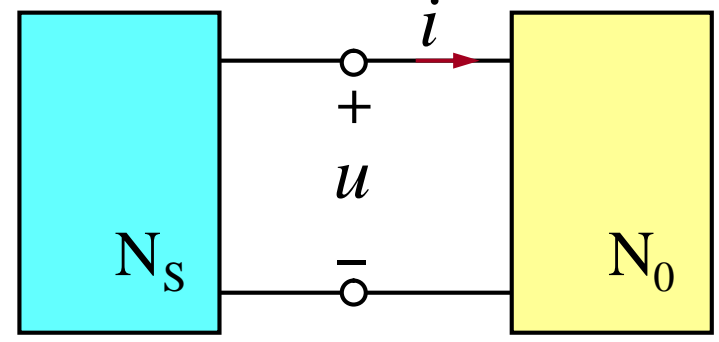

$$S \stackrel{\text{def}}{=} UI$$

S S
VA()

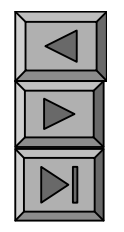

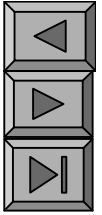

4. S P Q

S UI

P $UI\cos$ $S\cos$

Q $UI\sin$ $S\sin$

S $\sqrt{P^2 + Q^2}$

$\arctg \frac{Q}{P}$

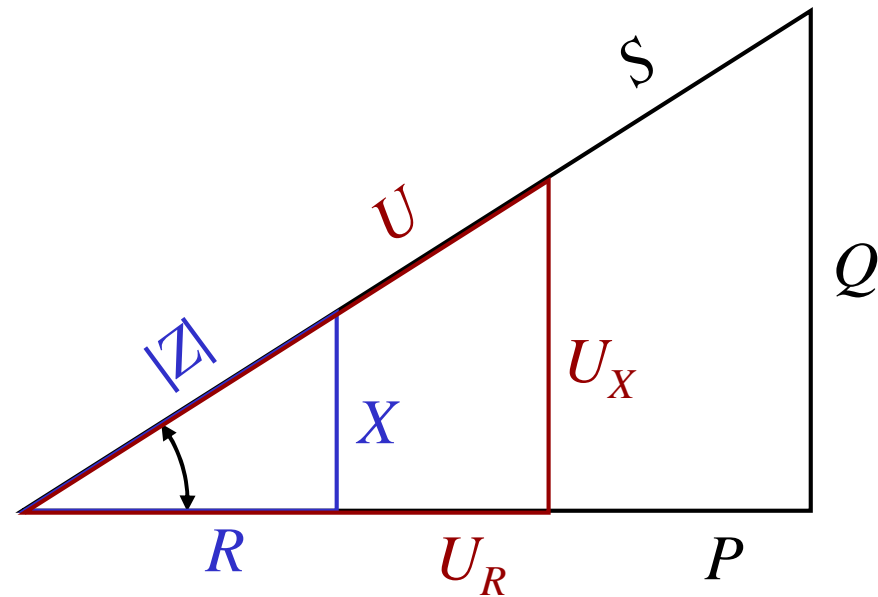

5. $R \quad L \quad C$

(1) $R \quad u \quad i$

$$i = \sqrt{2} I \cos t$$

$$u = \sqrt{2} U \cos t$$

$$p = ui = UI(1 + \cos 2t) \quad 0$$

$$p = 0 \quad R$$

$$P_R = UI \cos \phi = UI \quad I^2 R = U^2 G$$

$$Q_R = UI \sin \phi = 0$$

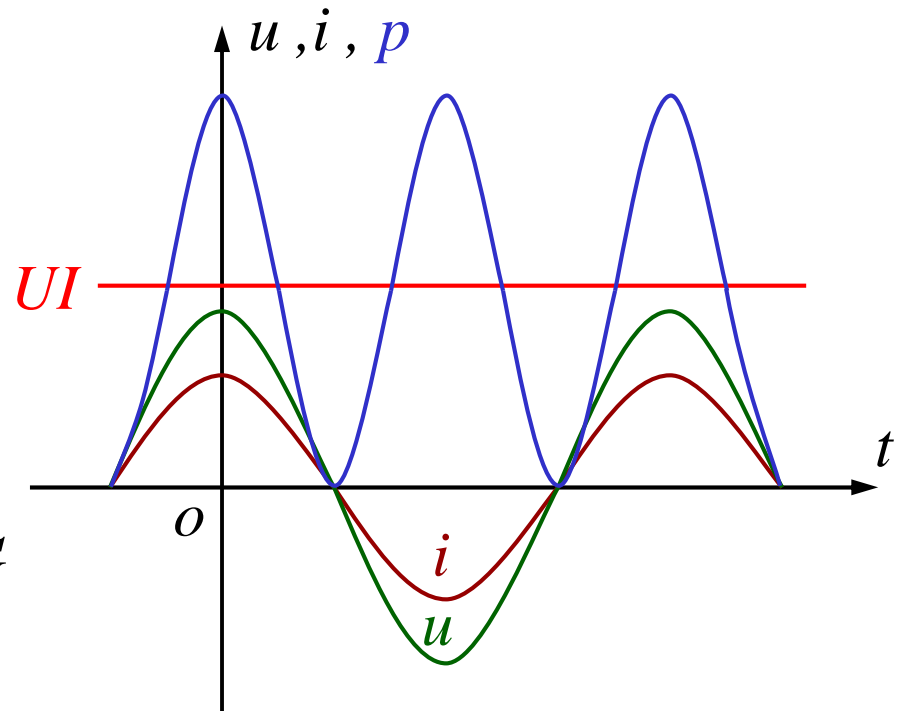
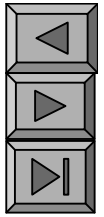
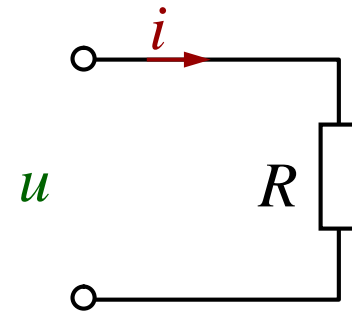

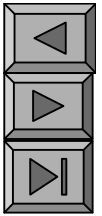

(2) L u i 90° ,

$$i = \sqrt{2} I \cos t$$

$$u = \sqrt{2} U \cos(t - 90^\circ)$$

$$p = ui = UI \sin 2t$$

$$P = UI \cos 90^\circ = 0$$

p

L

$$Q_L = UI \sin 90^\circ = UI = LI I$$

$$I^2 L = \frac{U^2}{L} = I^2 X_L$$

L

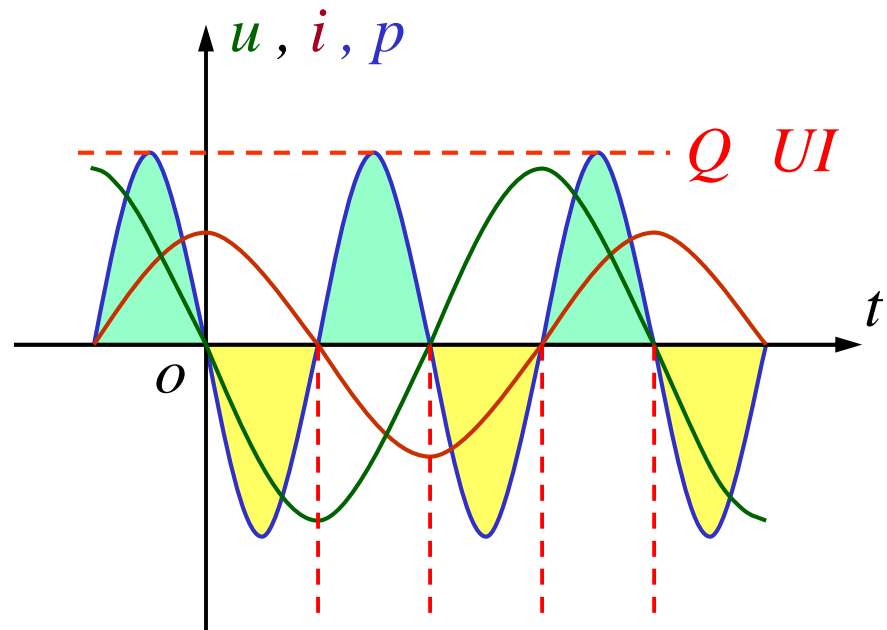
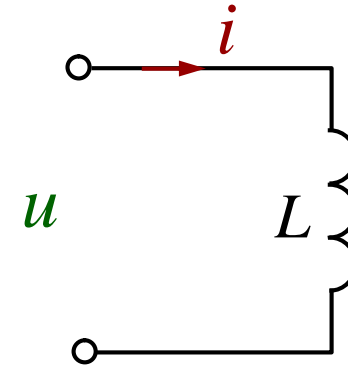

(3)

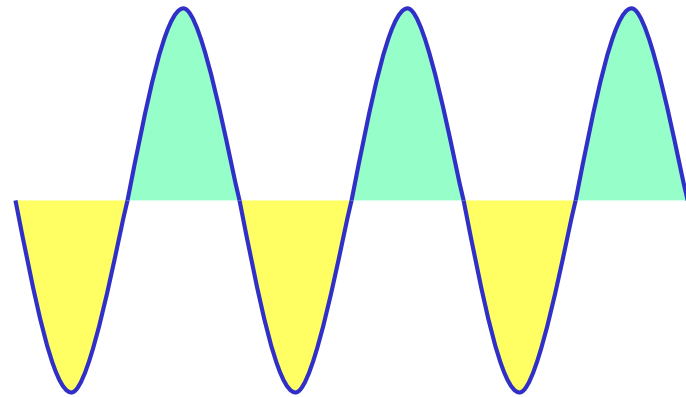
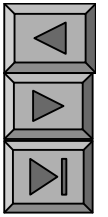

$R \quad L$

$R \quad L$

R

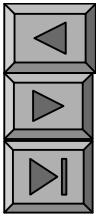
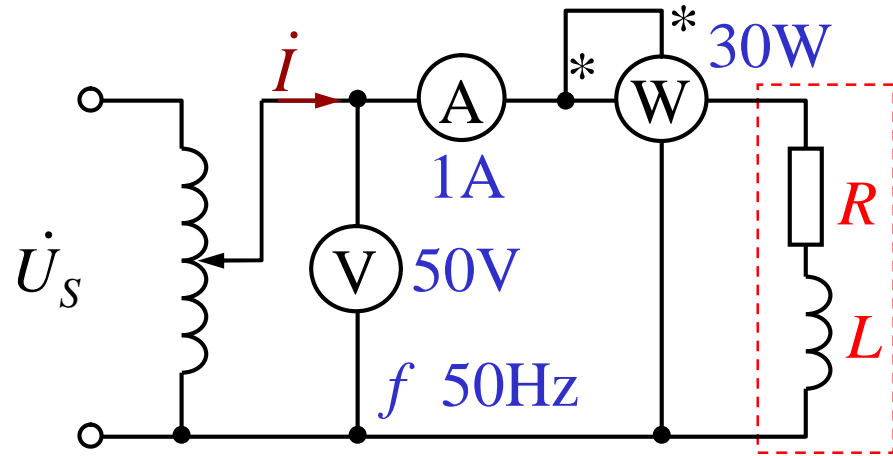

$$P = I^2 R = 30 \text{ W}$$

$$R = 30$$

$$L = \frac{40}{314} = 127 \text{ mH}$$

$$\cos \phi = \frac{P}{UI} = \frac{30}{50 \times 1} = 0.6$$

$$|Z| = \frac{U}{I} = 50$$

$$Z = 30 + j40$$

$$R = 30 \quad L = 40$$

9 5

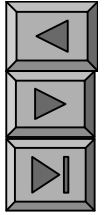

“ ”

1.

$$\dot{U} = U \underline{\angle}_u \quad \dot{I} = I \underline{\angle}_i$$

$$\underline{\bar{S}} \stackrel{\text{def}}{=} \dot{U} \dot{I}^* = UI \underline{\angle}_{u-i} = S \underline{\angle}$$

$$UI \cos \theta + j UI \sin \theta = P + jQ$$

$$\underline{\bar{S}} = P + jQ \quad S$$

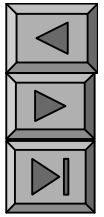

2.

$$\bar{S} = \dot{U} \dot{I}^* = Z \dot{I} \dot{I}^* = Z I^2 = R I^2 + jX I^2 = P + jQ$$

$$\bar{S} = \dot{U} \dot{I}^*$$

$$\bar{S}$$

P239 9-10 U 380V
 f 50Hz $\cos \varphi_1$ 0.6 P_1 20kW
 $\cos \varphi$ 0.9 C

$\cos \varphi_1$ 0.6 φ_1 53.13°
 Q_1 $P_1 \tan \varphi_1$ $\tan 53.13^\circ$

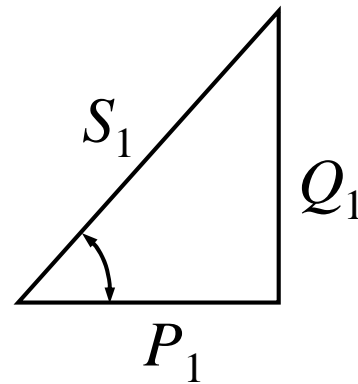

26.67 kvar

RL

\bar{S}_1 $P_1 + jQ_1$ C
 20 + j26.67 kVA

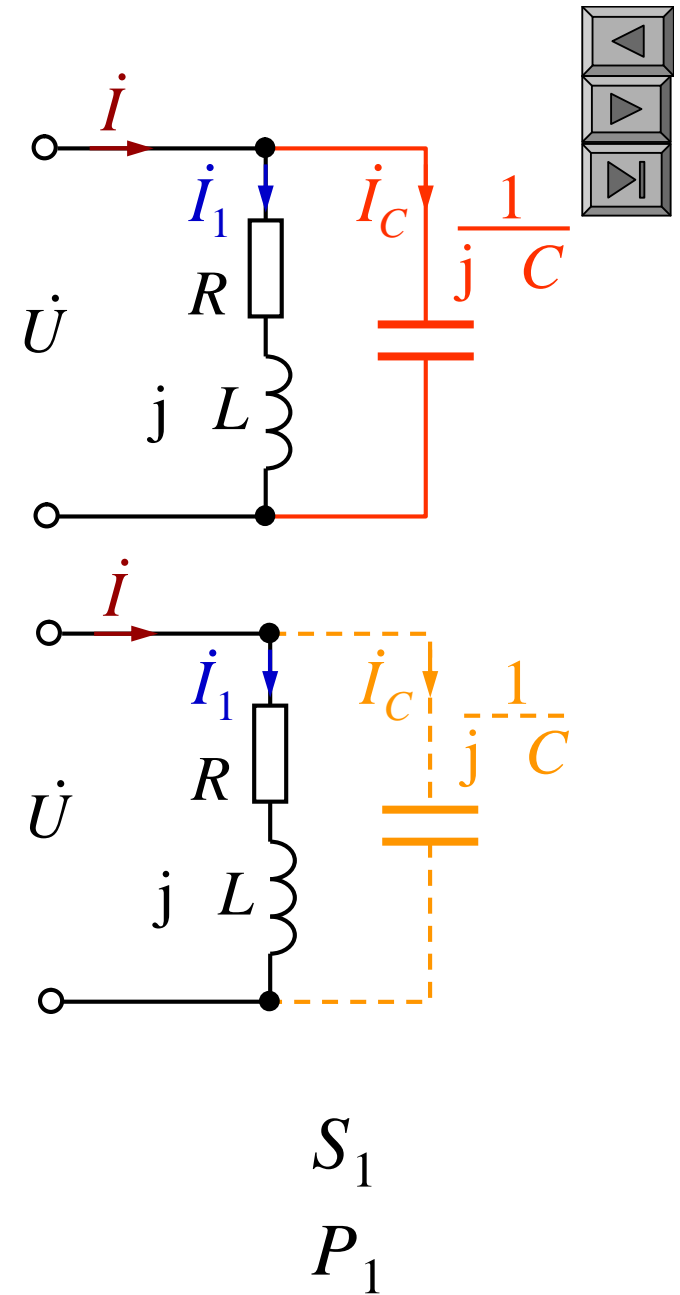

$$\begin{aligned} C & \quad \bar{S}_C \quad 0 \quad jQ_C \\ \bar{S} & \quad \bar{S}_1 \quad \bar{S}_C \quad P_1 \quad j(Q_1 \quad Q_C) \\ & \quad \cos \quad 0.9 \\ & \quad 25.84^\circ \end{aligned}$$

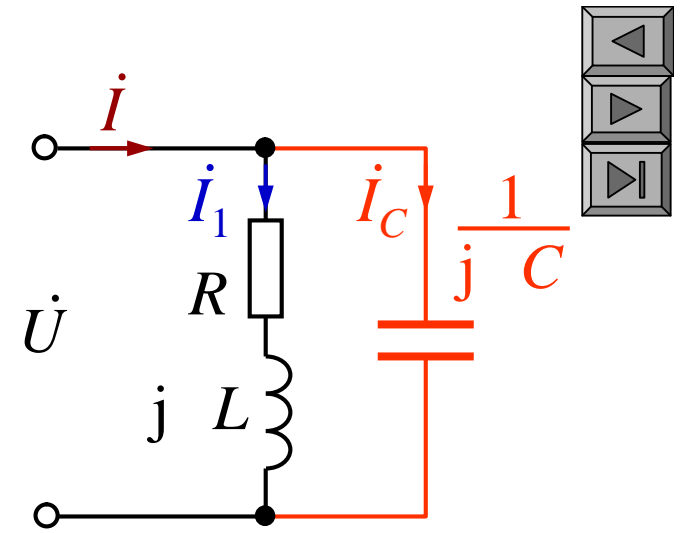

$$Q_C \quad 16.98 \quad 36.36 \text{ kvar}$$

$$\begin{aligned} Q & \quad Q_1 \quad Q_C \quad P_1 \text{tg} \\ & \quad 9.69 \text{ kvar} \end{aligned}$$

$$\begin{aligned} Q_C & \quad CU^2 \\ C & \quad \frac{Q_C}{U^2} \end{aligned}$$

$$\begin{aligned} C & \quad 9.69 \quad Q_1 \\ Q_C & \quad 9.69 \quad 26.67 \text{ kvar} \end{aligned}$$

$$C = \frac{19.68 \cdot 10^3}{314 \cdot 380^2} \text{ F}$$

$$C \quad I_1 \quad I_1 \sin z_1$$

$$I_C$$

$$I_1 \quad U \cos z_1 \quad P_1 \quad \frac{P_1}{U \cos z}$$

$$I_C \quad CU$$

$$C \quad \frac{P_1}{U^2} (\tan z_1 \quad \tan z)$$

$$C \quad 375 \quad F$$

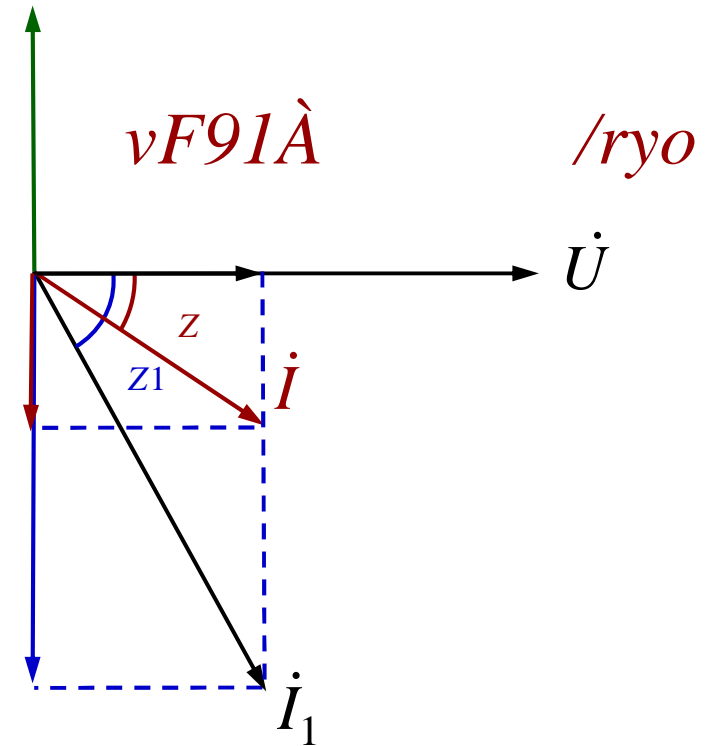
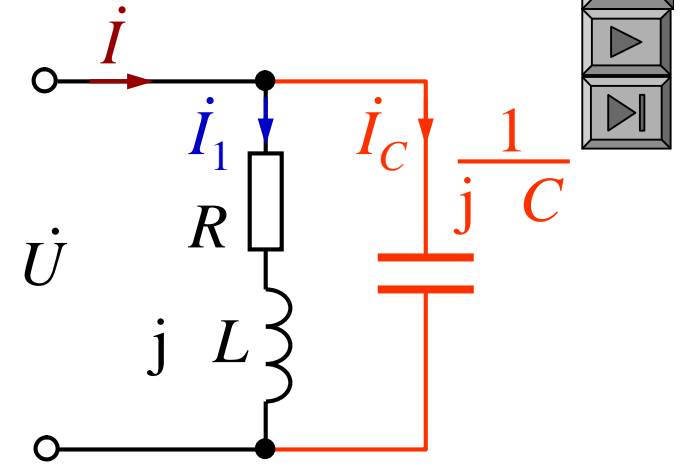

3

C

$$Y = Y_1 + Y_C$$

$$Y = Y \cos \varphi_Y + j Y \sin \varphi_Y$$

$$Y_1 = Y_1 \cos \varphi_{Y1} + j Y_1 \sin \varphi_{Y1}$$

$$Y \cos \varphi_Y + j Y \sin \varphi_Y = Y_1 \cos \varphi_{Y1} + j Y_1 \sin \varphi_{Y1} + j C$$

$$Y \sin \varphi_Y = Y_1 \sin \varphi_{Y1} + C$$

$$P_1 = U(U Y_1) \cos \varphi_{Y1} = Y_1 \frac{P_1}{U^2 \cos \varphi_{Y1}} = Y_1 z(\varphi_{Y1})$$

$$P = U(U Y) \cos \varphi_Y = Y \frac{P_1}{U^2 \cos \varphi_Y} = Y z(\varphi_Y)$$

$$C = \frac{P_1}{U^2} (\operatorname{tg} \varphi_Y - \operatorname{tg} \varphi_{Y1}) = z(\varphi_{Y1}) - z(\varphi_Y)$$

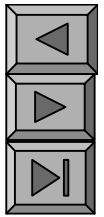
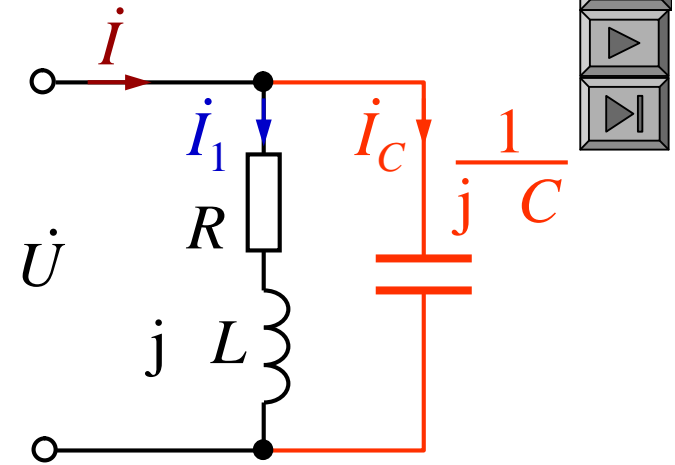

$$I_1 = \frac{P_1}{U \cos \phi_1} = \frac{20 \times 10^3}{380 \times 0.6}$$

$$C = \frac{P_1}{U^2} I_1$$

$$I = \frac{P_1}{U \cos \phi} = \frac{20 \times 10^3}{380 \times 0.9}$$

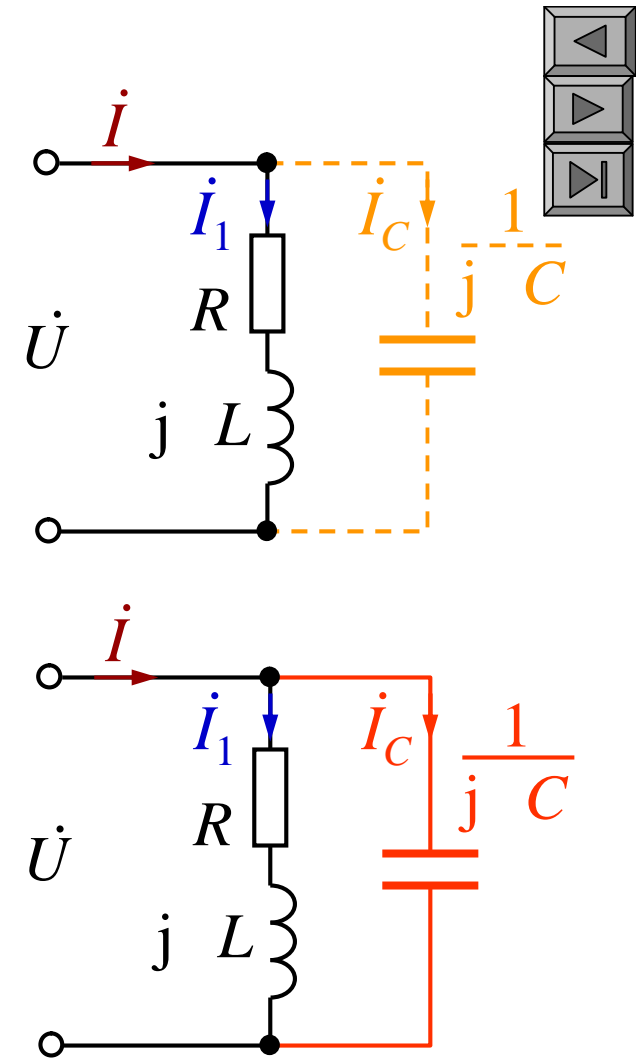

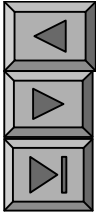

9 6

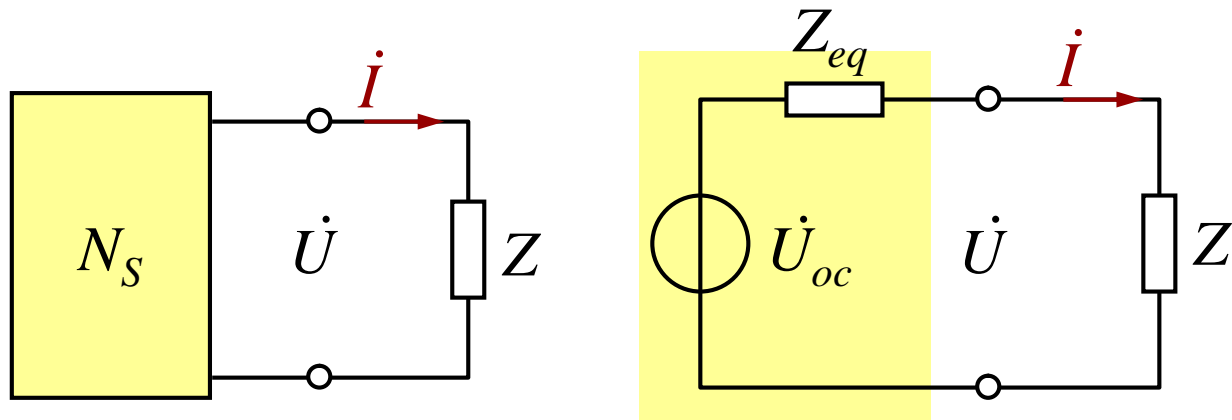

$Y \quad Y_{eq}^*$

Z

P_{max}

Z

$Z \quad R \quad jX \quad Z_{eq} \quad R_{eq} \quad jX_{eq}$

$X \quad X_{eq} \quad 0$
 $\left. \begin{array}{l} \frac{dP}{dR} \quad 0 \end{array} \right\}$

$$P = I^2 R = \frac{U_{oc}^2}{|Z + Z_{eq}|^2} R$$

$$P_{max} = \frac{R U_{oc}^2}{(R + R_{eq})^2 + (X + X_{eq})^2}$$

$Z \quad R_{eq} \quad jX_{eq} \quad Z_{eq}^*$

$$P_{max} = \frac{U_{oc}^2}{4R_{eq}}$$

