



- 1.
- 2.
- 3.

1.

2.Y

()

3.

4.

5.

- 1.
- 2.

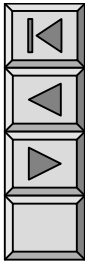

§ 11-1

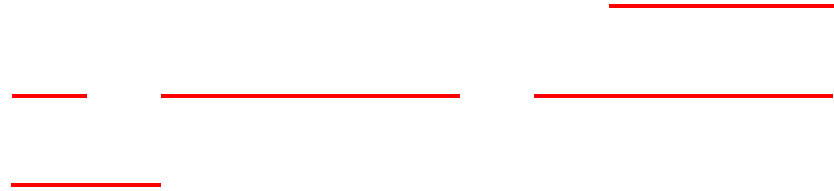
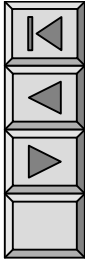



1.

120° () ω

(1)



$$u_A = \sqrt{2}U \cos(\omega t)$$

$$u_B = \sqrt{2}U \cos(\omega t - 120^\circ)$$

$$u_C = \sqrt{2}U \cos(\omega t + 120^\circ)$$

$$a = 1 \quad 120^\circ$$



$$\dot{U}_A = U \angle 0^\circ$$

$$\dot{U}_B = U \angle -120^\circ = a^2 \dot{U}_A$$

$$\dot{U}_C = U \angle 120^\circ = a \dot{U}_A$$



*

$$a = 1 \angle 120^\circ$$

$$a = 1 \angle 120^\circ$$

$$a^2 = 1 \angle 240^\circ = 1 \angle -120^\circ = 1 \angle a$$

$$a^2 = 1 \angle 120^\circ$$

$$\dot{U}_A = U \angle 0^\circ \quad \dot{U}_B = \dot{U}_A \angle 120^\circ$$

$$\dot{U}_B = a^2 \dot{U}_A$$

$$\dot{U}_A = \dot{U}_B \angle 120^\circ$$

$$a = -\frac{1}{2} + j\frac{\sqrt{3}}{2}$$

$$\dot{U}_A = a \dot{U}_B$$

$$1 - a = \frac{3}{2} - j\frac{\sqrt{3}}{2} = \sqrt{3} \angle -120^\circ$$

$$\dot{U}_C = a \dot{U}_A$$

$$a^2 \dot{U}_B$$

$$1 - a^2 = \frac{3}{2} + j\frac{\sqrt{3}}{2} = \sqrt{3} \angle 120^\circ$$

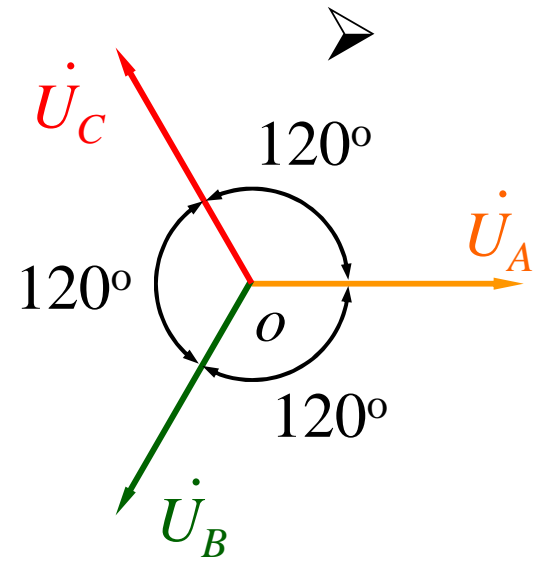
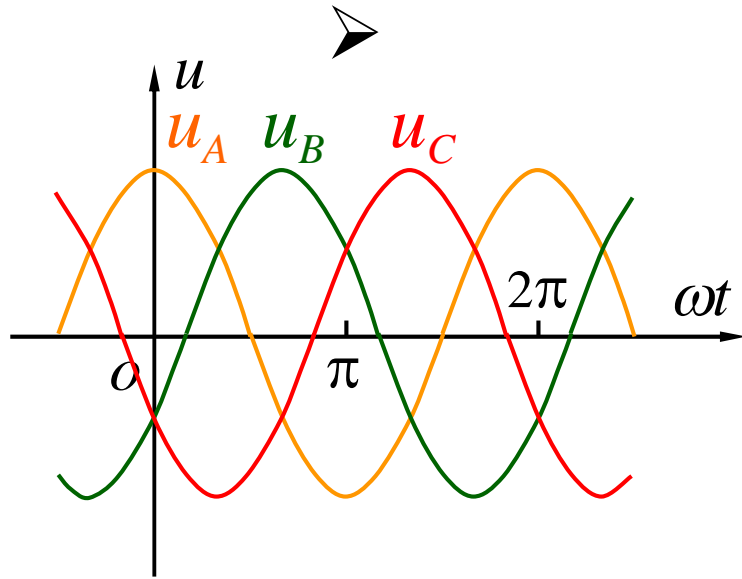

(2)

_____ ()

_____120°

120°

A B C A



$$\underline{\underline{\dot{U}_A + \dot{U}_B + \dot{U}_C = 0}}$$

$$u_A + u_B + u_C = 0$$

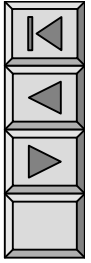

$$\dot{U}_A = \dot{U}_B = \dot{U}_C$$

2.

(1) Y()



N ()



A B C

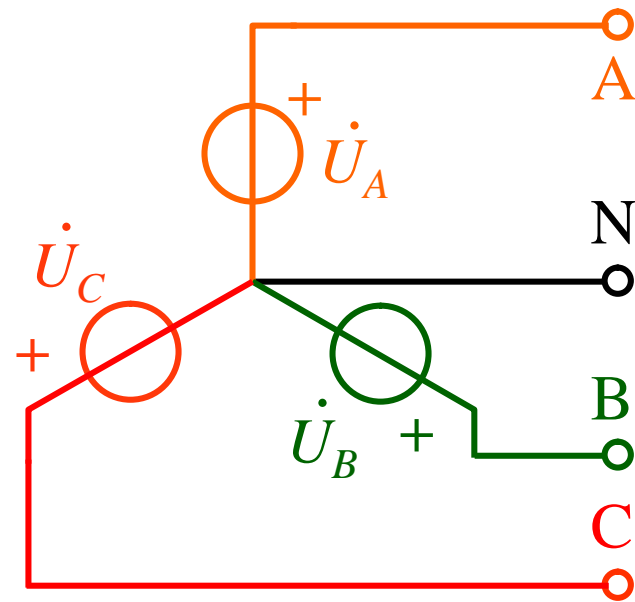



(2)



B C



(



)

Y

A

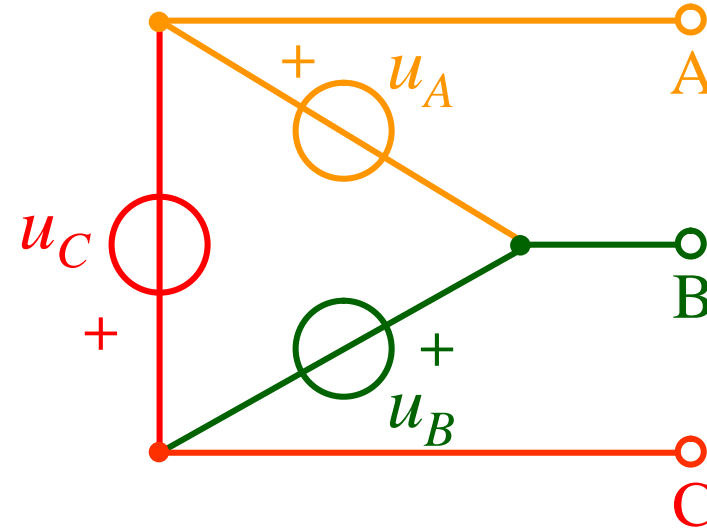

3.



Y



(1) “ ”

Y-Y Y-
-Y -

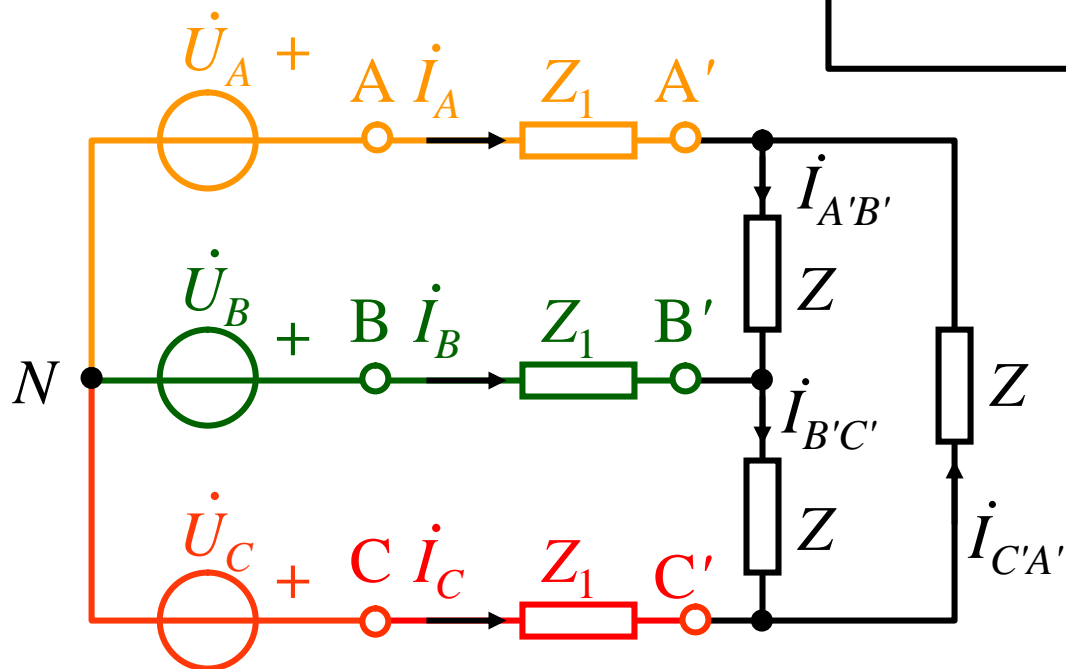
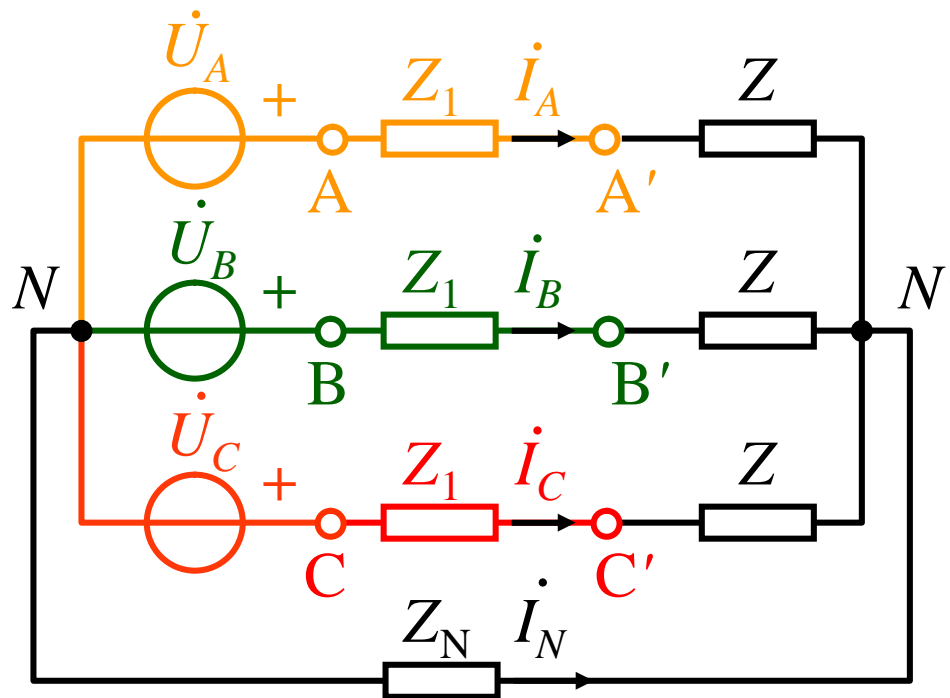

Y₀-Y₀

Y-Y

(2) “

”

“

”

(3) “

”

(4)

“

”

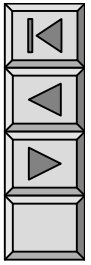

§ 11-2

()

()

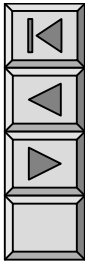

1. Y

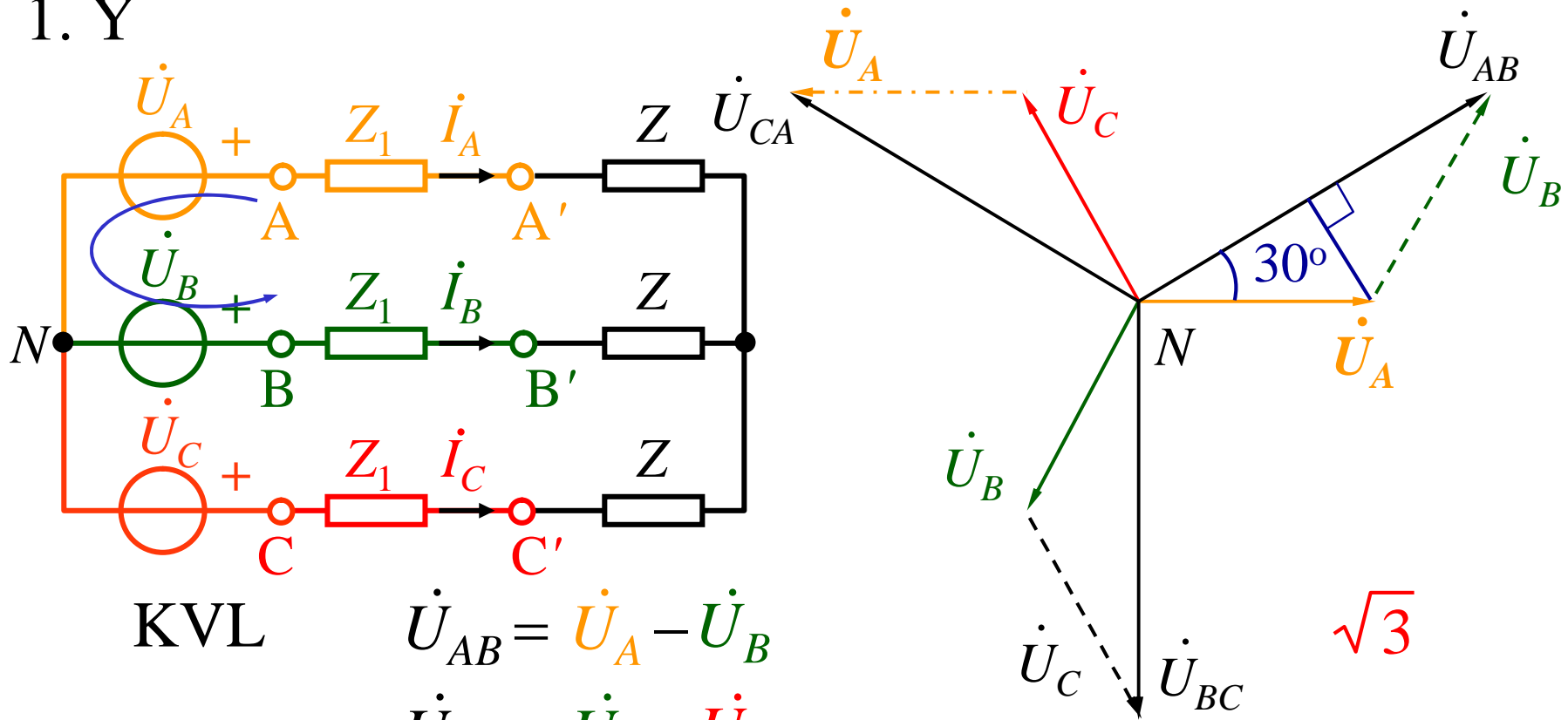

KVL

$$\dot{U}_{AB} = \dot{U}_A - \dot{U}_B$$

$$\dot{U}_{BC} = \dot{U}_B - \dot{U}_C$$

$$\dot{U}_{CA} = \dot{U}_C - \dot{U}_A$$

$$U_{AB} = 2 \times U_A \cos 30^\circ = \sqrt{3} U_A$$

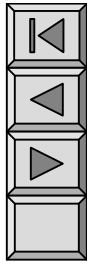
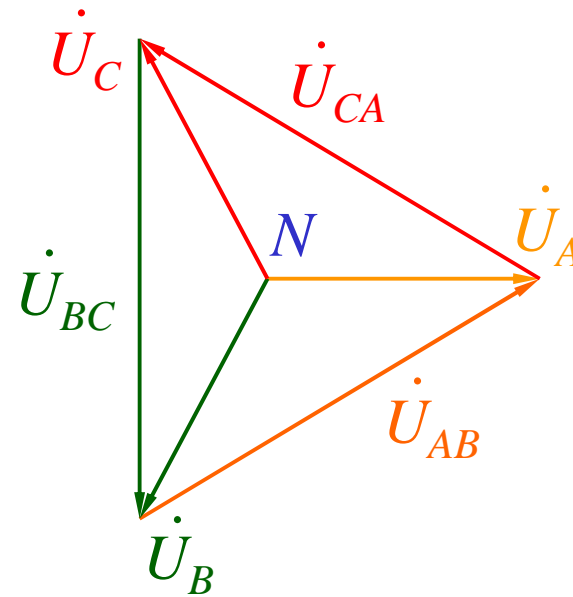
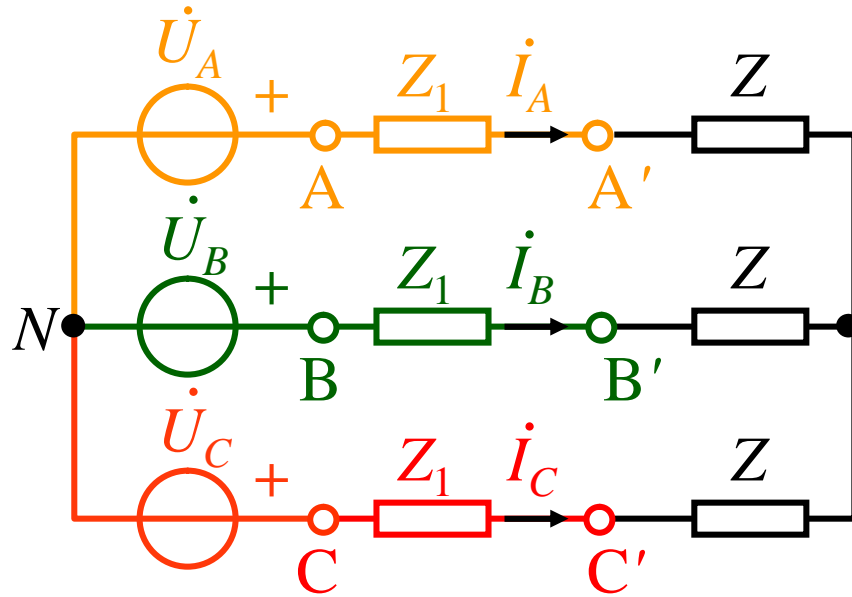

$$\dot{U}_A = U \angle 0^\circ \quad \dot{U}_B = a^2 \dot{U}_A \quad \dot{U}_C = a \dot{U}_A$$

$$\dot{U}_{AB} = \sqrt{3} \dot{U}_A \angle 30^\circ$$

$$\dot{U}_{BC} = a^2 \dot{U}_{AB} \quad \dot{U}_{CA} = a \dot{U}_{AB}$$

$$\dot{U}_{AB} + \dot{U}_{BC} + \dot{U}_{CA} = 0$$



Y
 \dot{U}_A \dot{U}_B \dot{U}_C
 \dot{U}_{AB} \dot{U}_{BC} \dot{U}_{CA}

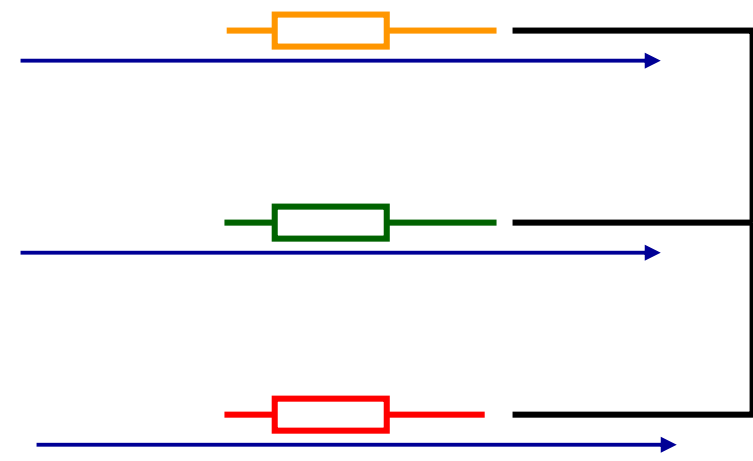

Y
Y
Y

30°!

2.

$$\dot{U}_{AB} = \dot{U}_A \quad \dot{U}_{BC} = \dot{U}_B \quad \dot{U}_{CA} = \dot{U}_C$$

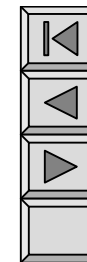
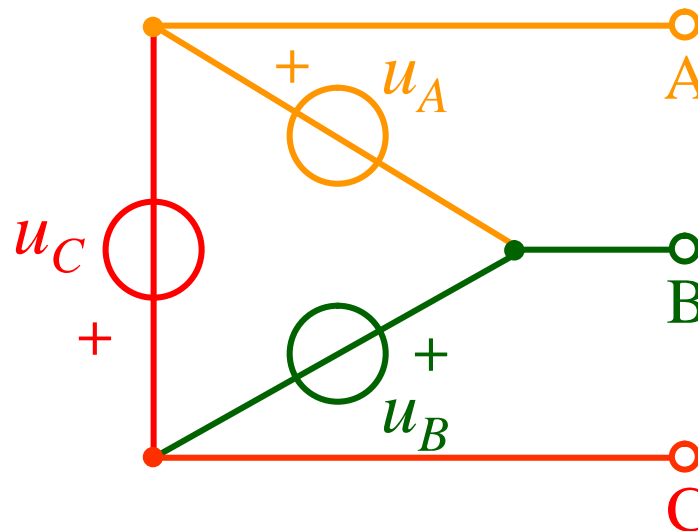

$$\dot{I}_{A'B'} \quad \dot{I}_{B'C'} \quad \dot{I}_{C'A'} \\ \dot{I}_{A'B'} \quad \dot{I}_{B'C'} \quad 120^\circ$$

$$\dot{I}_{A'B'} = a \dot{I}_{B'C'}$$

$$\dot{I}_{B'C'} \quad \dot{I}_{C'A'} \quad 120^\circ :$$

$$\dot{I}_{B'C'} = a \dot{I}_{C'A'}$$

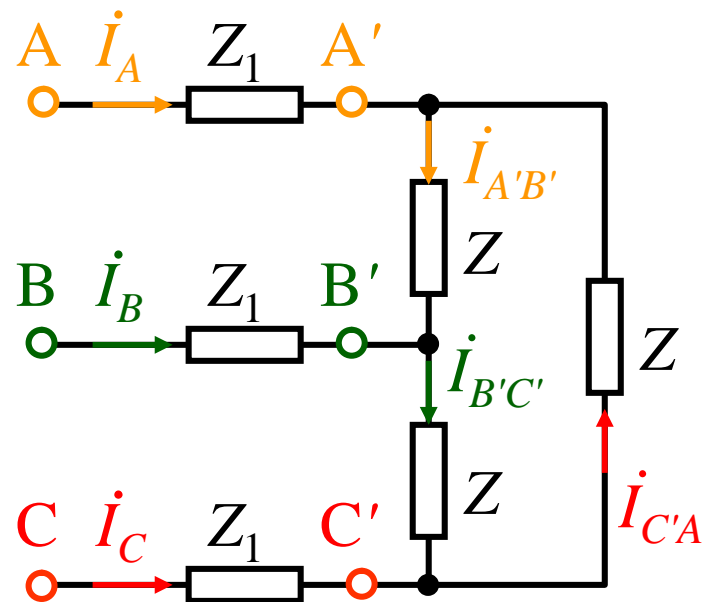



$$\dot{I}_A = \dot{I}_{A'B'} \quad \dot{I}_{C'A'} = (1 - a) \dot{I}_{A'B'}$$

$$\dot{I}_{A'B'} \angle 30^\circ$$

$$\dot{I}_B = \dot{I}_{B'C'} \quad \dot{I}_{A'B'} = (1 - a) \dot{I}_{B'C'}$$

$$\dot{I}_{B'C'} \angle 30^\circ$$

$$\dot{I}_C = \dot{I}_{C'A'} \quad \dot{I}_{B'C'} = (1 - a) \dot{I}_{C'A'}$$

$$\dot{I}_{C'A'} \angle 30^\circ$$

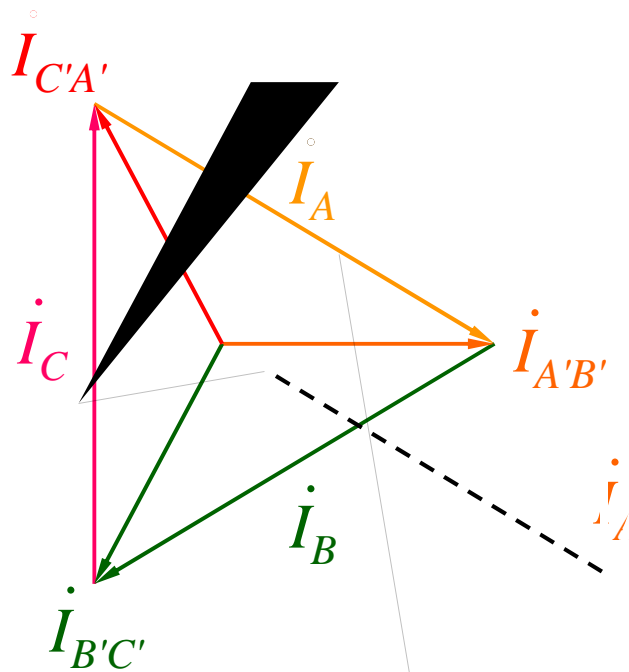



()

30°

$\sqrt{3}$

KCL

$$\underline{\underline{\dot{I}_A + \dot{I}_B + \dot{I}_C = 0}}$$

$$\underline{\underline{\dot{I}_{AB} + \dot{I}_{BC} + \dot{I}_{CA} = 0}}$$

§ 11-3

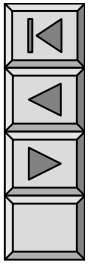

1. $Y_0 - Y_0$ $Y - Y$

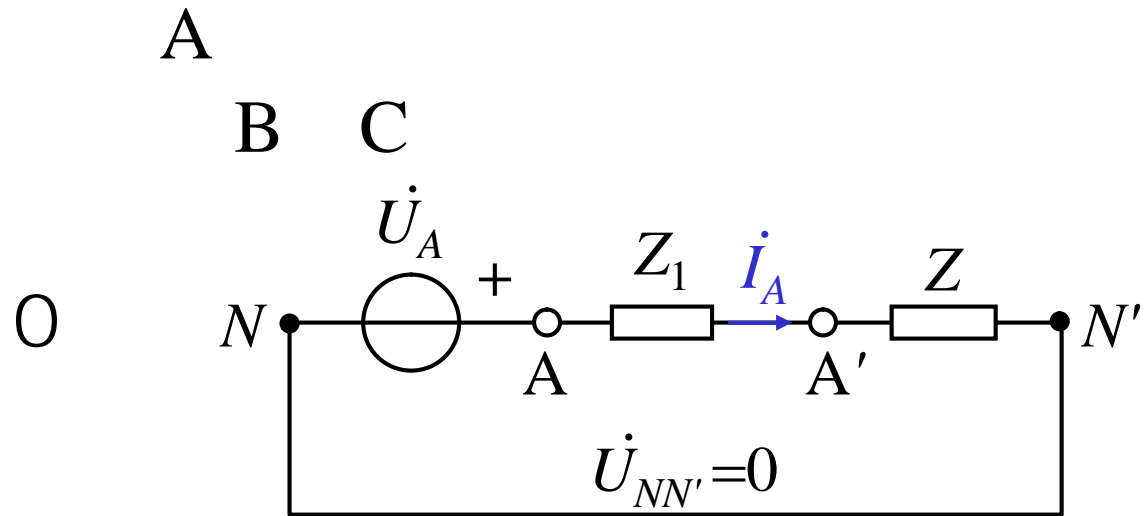

2. $Y -$
 Y

$Y - Y$

$$Z_Y = \frac{1}{3} Z$$

3.

- -Y

Y-Y

Y

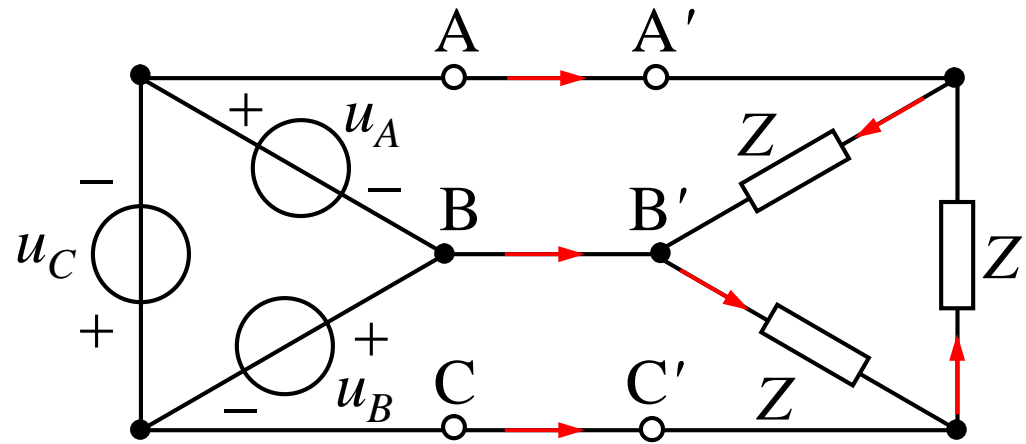
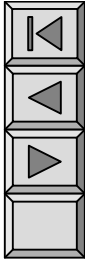



Y

Y

Y—Y

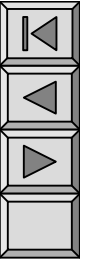



1 $u_{AB} = 380\sqrt{2} \cos(\omega t + 30^\circ) \text{ V}$ $Z_1 = (1 + j2)\Omega$
 $Z = (5 + j6)\Omega$

Y-Y ()
 (A)

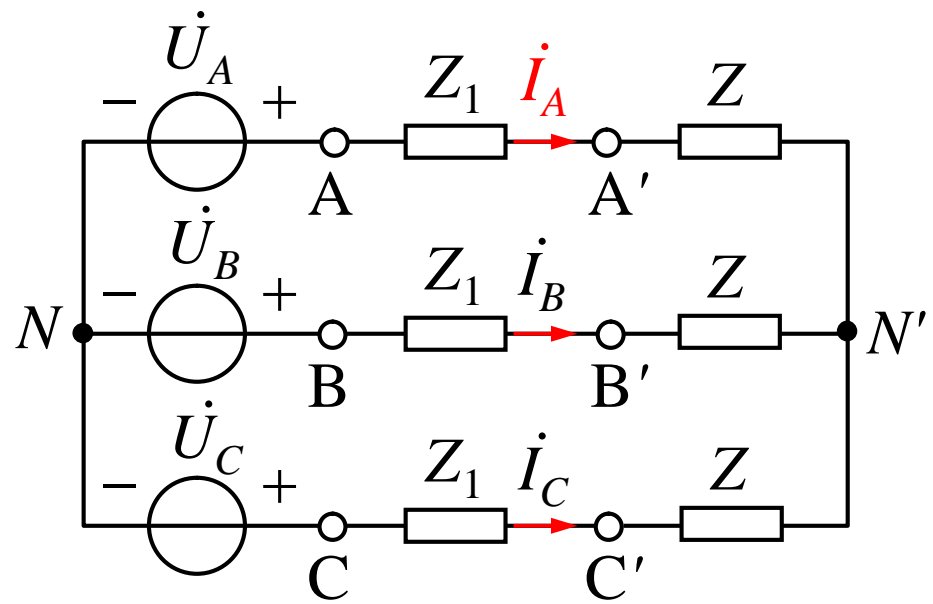

$$\dot{U}_A = \frac{\dot{U}_{AB}}{\sqrt{3} \angle 30^\circ} = 220 \angle 0^\circ \text{ V}$$

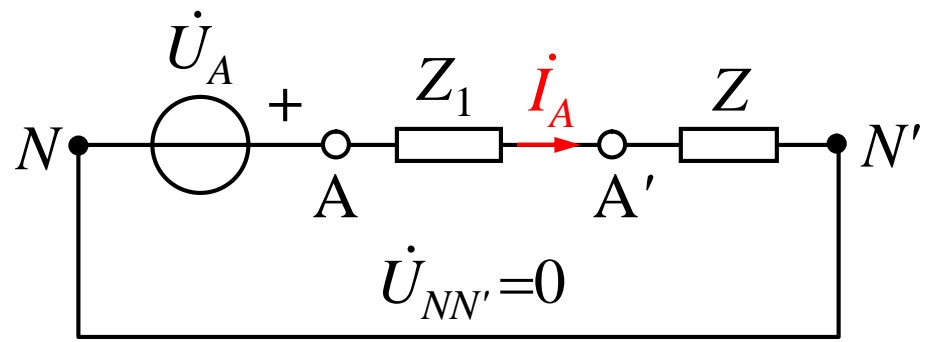

$$\dot{U}_A = \frac{\dot{U}_{AB}}{\sqrt{3} / 30^\circ} = 220 \angle 0^\circ \text{ V}$$

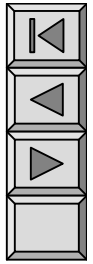
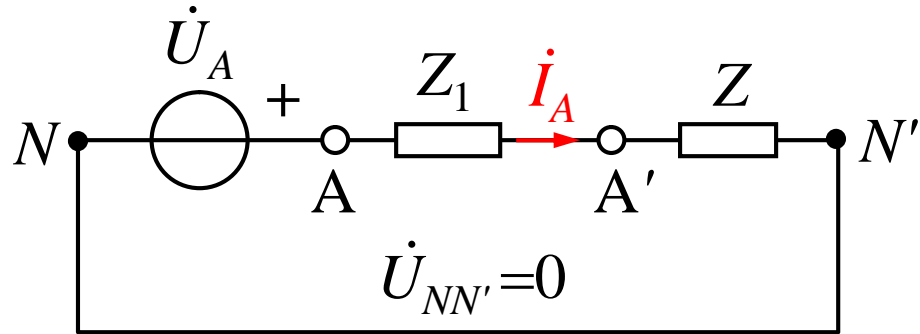

$$\dot{I}_A = \frac{\dot{U}_A}{Z_1 + Z} = \frac{220 \angle 0^\circ}{1 + j2 + 5 + j6} = 22 \angle 53.1^\circ \text{ A}$$

$$\dot{I}_B = a^2 \dot{I}_A = 22 \angle 173.1^\circ \text{ A}$$

$$\dot{I}_C = a \dot{I}_A = 22 \angle 66.9^\circ \text{ A}$$

$$\dot{U}_{A'} = Z \dot{I}_A$$

$$\dot{U}_{B'} \quad \dot{U}_{C'}$$

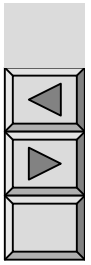



$$\dot{U}_{AN'} = \dot{I}_A Z' = 136.8 \angle -6.3^\circ \text{ V}$$

$$\begin{aligned} \dot{U}_{A'B'} &= \sqrt{3} \dot{U}_{AN'} \angle 30^\circ \\ &= 236.9 \angle 23.7^\circ \text{ V} \end{aligned}$$

$$\dot{U}_{B'C'} = 236.9 \angle -96.3^\circ \text{ V}$$

$$\dot{U}_{C'A'} = 236.9 \angle 143.7^\circ \text{ V}$$

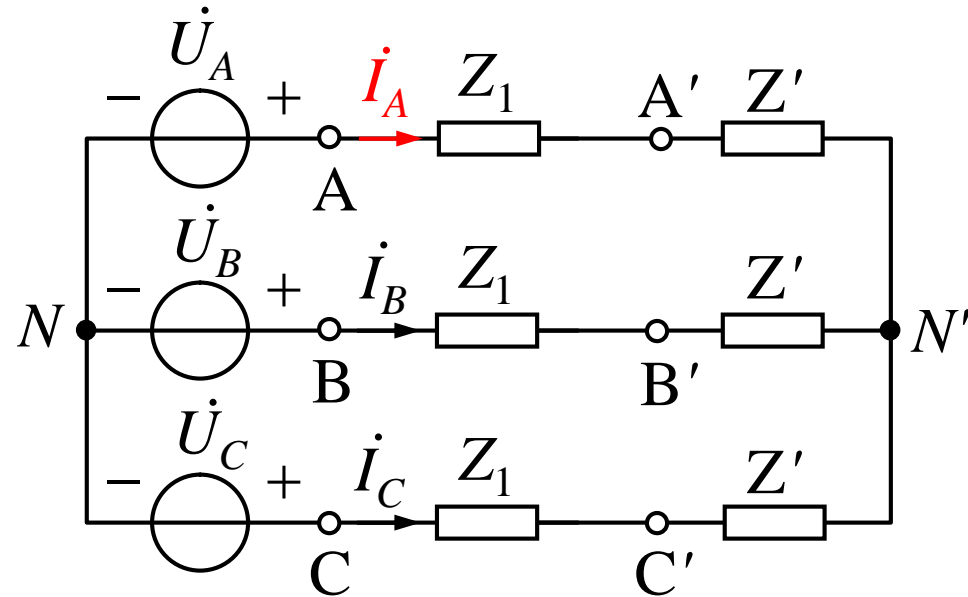

$$\dot{I}_{A'B'} = \frac{\dot{U}_{A'B'}}{Z} = 9.9 \angle 13.2^\circ \text{ A}$$

$$\dot{I}_{B'C'} = 9.9 \angle 133.2^\circ \text{ A}$$

$$\dot{I}_{C'A'} = 9.9 \angle 106.8^\circ \text{ A}$$

3

$$|Z_1|=10\Omega \quad \cos\varphi_1=0.6($$

$$Z_N=1+j2\Omega$$

380V

$$) \quad Z_2=-j50\Omega$$

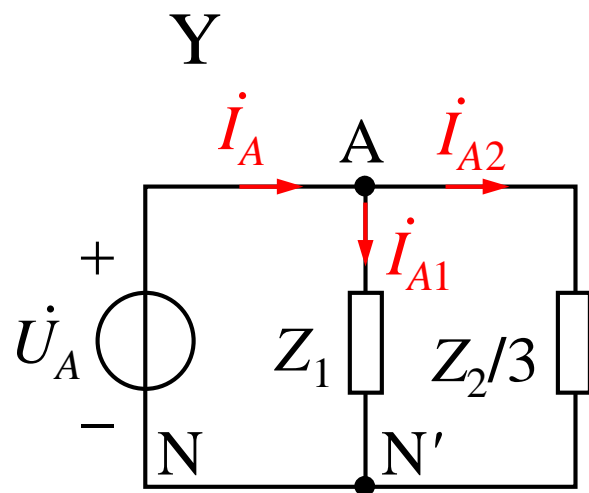

$$\dot{U}_A = 220 \angle 0^\circ \text{ V}$$

$$\dot{U}_{AB} = 380 \angle 30^\circ \text{ V}$$

$$\cos\varphi_1=0.6($$

$$\varphi_1=53.1^\circ$$

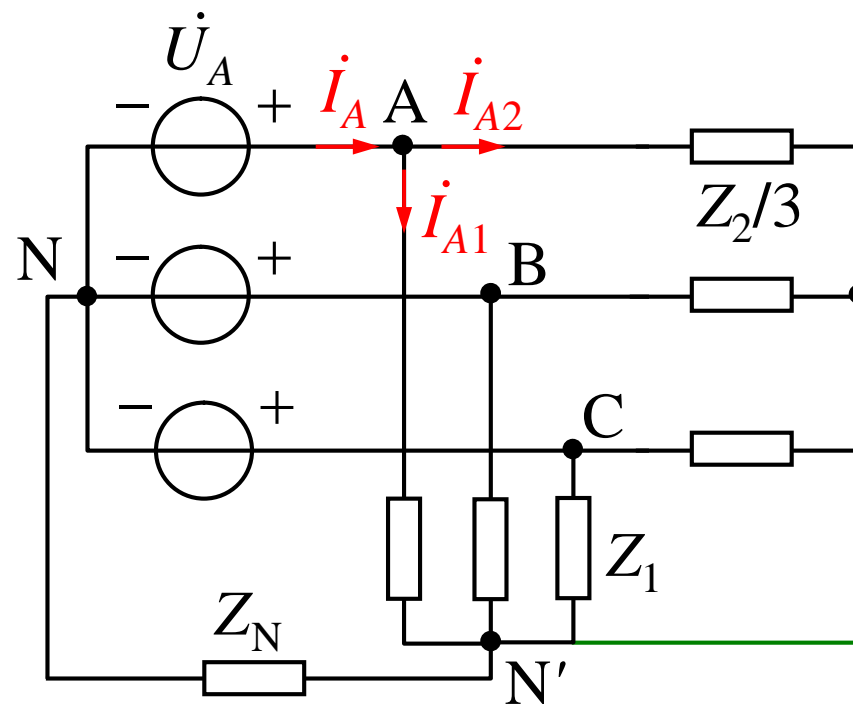

$$Z_1=10 \angle 53.1^\circ = 6+j8 \Omega$$

$$Y \quad Z_2/3=-j50/3 \Omega$$

$$\dot{U}_A = 220 \angle 0^\circ \text{ V} \quad Z_2/3 = -j50/3 \Omega$$

$$Z_1 = 10 \angle 53.1^\circ = 6 + j8 \Omega$$

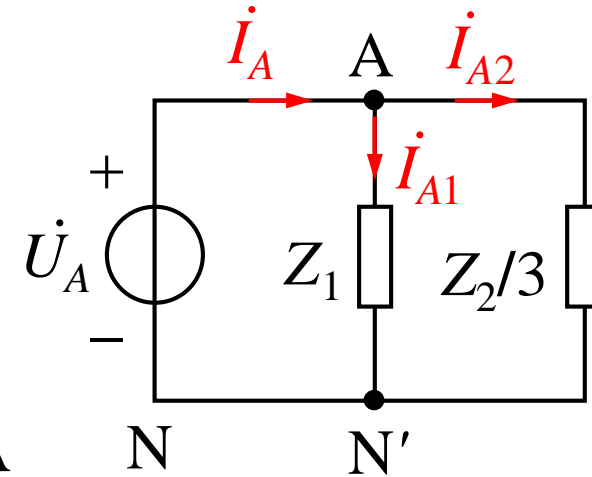

$$\dot{I}_{A1} = \frac{\dot{U}_A}{Z_1} = 22 \angle 53.1^\circ = 13.2 - j17.6 \text{ A}$$

$$\dot{I}_{A2} = \frac{\dot{U}_A}{Z_2/3} = j13.2 \text{ A}$$

$$\dot{I}_A = \dot{I}_{A1} + \dot{I}_{A2} = 13.9 \angle 18.4^\circ \text{ A}$$

B C

$$\dot{I}_B = 13.9 \angle 138.4^\circ \text{ A}$$

$$\dot{I}_C = 13.9 \angle 101.6^\circ \text{ A}$$

$$\dot{I}_{A1} = 22 \angle 53.1^\circ \text{ A}$$

$$\dot{I}_{B1} = 22 \angle 173.1^\circ \text{ A}$$

$$\dot{I}_{C1} = 22 \angle 66.9^\circ \text{ A}$$

$$\dot{I}_{A2} = \frac{\dot{U}_A}{Z_2/3} = j13.2 \text{ A}$$

$$\begin{aligned} \dot{I}_{AB2} &= \frac{1}{\sqrt{3}} \dot{I}_{A2} \angle 30^\circ \\ &= 7.62 \angle 120^\circ \text{ A} \end{aligned}$$

$$\dot{I}_{BC2} = 7.62 \angle 0^\circ \text{ A}$$

$$\dot{I}_{CA2} = 7.62 \angle -120^\circ \text{ A}$$

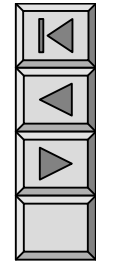
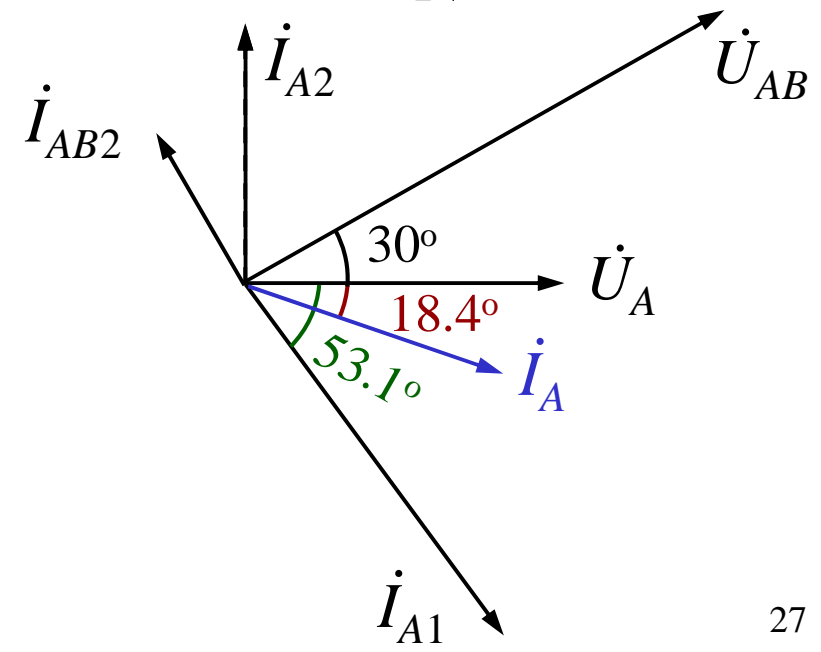
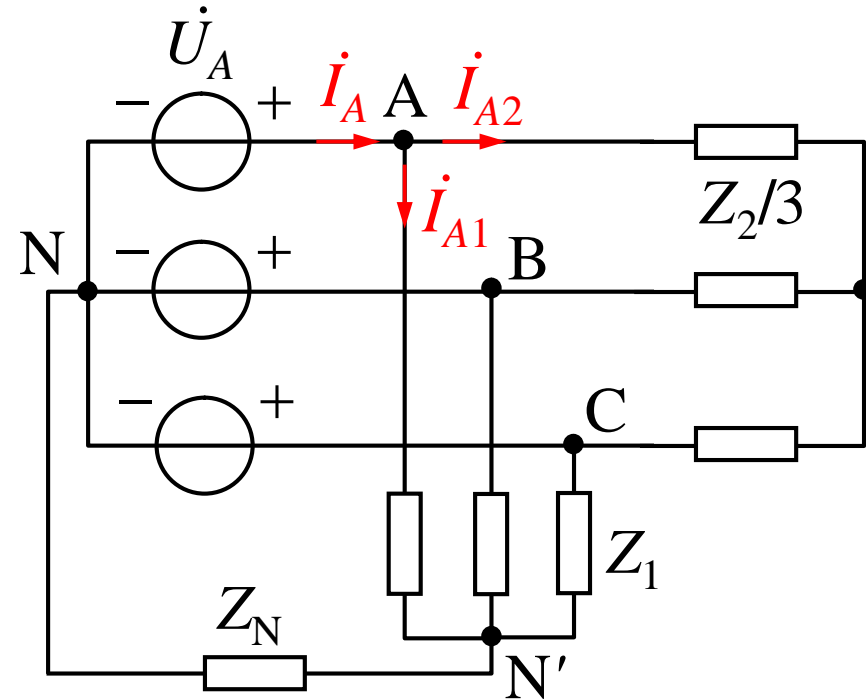

§ 11-4

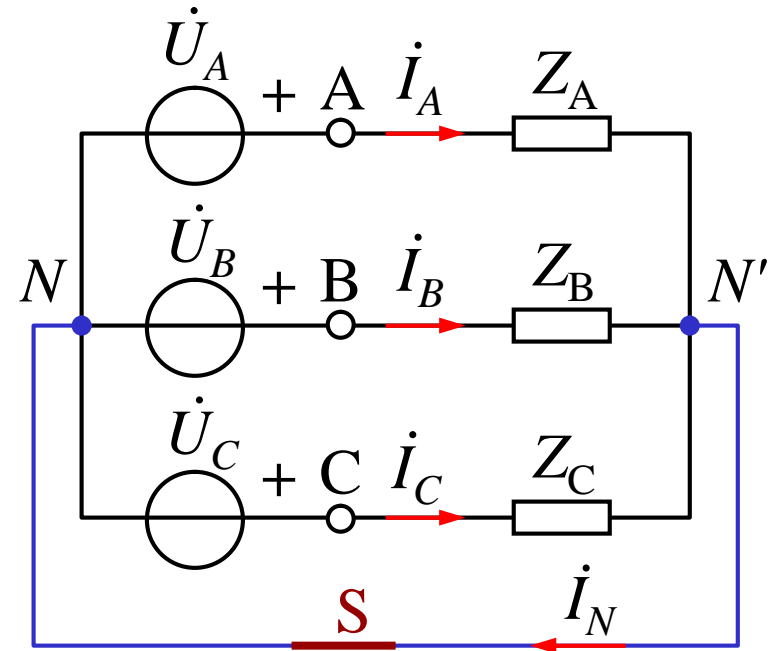
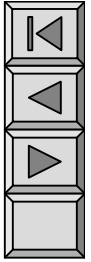

1. $Y_0 - Y_0$
 $Z_N = 0$

$$U_{NN'} = 0$$

2. -

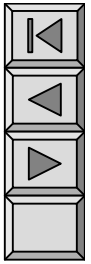
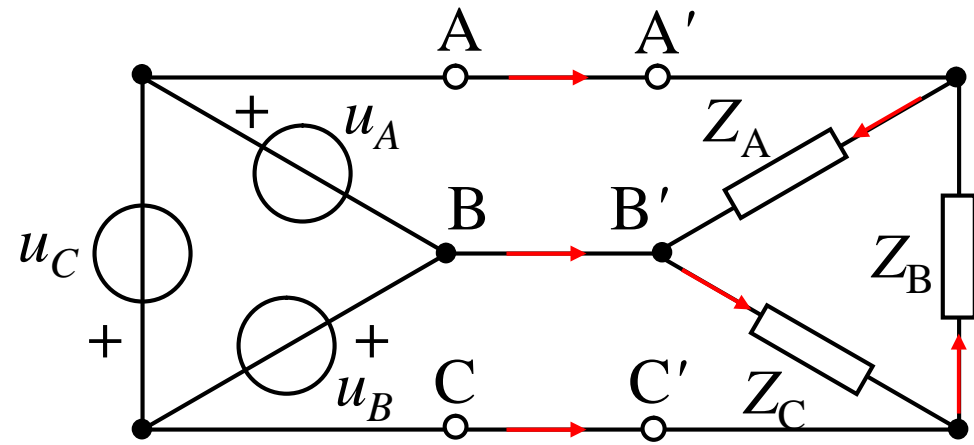

3. Y-Y

$$U_{NN'} = 0 \quad N$$

$$N'$$

$$\dot{U}_{N'N} = \frac{\dot{U}_A Y_A + \dot{U}_B Y_B + \dot{U}_C Y_C}{Y_A + Y_B + Y_C}$$

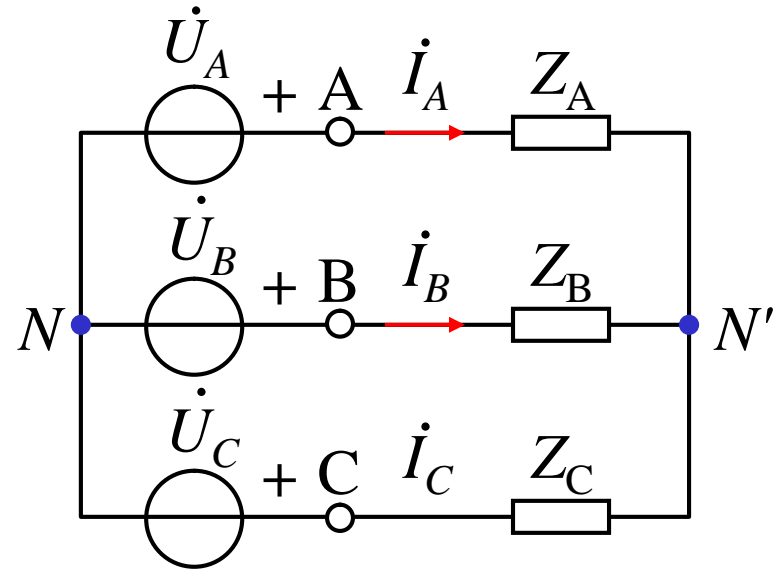

Y

4. Y

1

$$Z_N = 0$$

220V

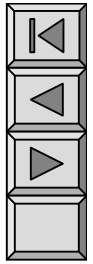
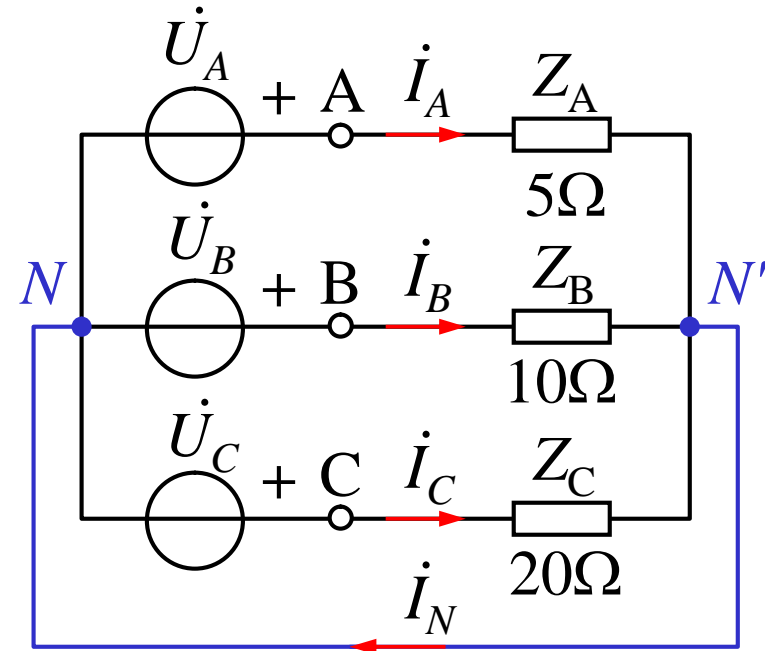

$$\dot{U}_A = 220 \quad 0^\circ \text{ V}$$

$$\dot{I}_A = \frac{\dot{U}_A}{Z_A} = \frac{220 \quad 0^\circ}{5} = 44 \quad 0^\circ \text{ A}$$

$$\dot{I}_B = \frac{\dot{U}_B}{Z_B} = 22 \angle -120^\circ \text{ A} \quad \dot{I}_C = \frac{\dot{U}_C}{Z_C} = 11 \angle 120^\circ \text{ A}$$

$$\dot{I}_N = \dot{I}_A + \dot{I}_B + \dot{I}_C = 29.1 \angle -19^\circ \text{ A}$$

2

A

A

A

A

$$\dot{I}_A = 0$$

B

C



$$\dot{I}_B = \frac{\dot{U}_B}{Z_B} = 22 \angle -120^\circ \text{ A}$$

$$\dot{I}_C = \frac{\dot{U}_C}{Z_C} = 11 \angle 120^\circ \text{ A}$$

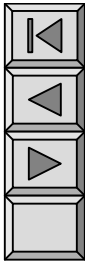
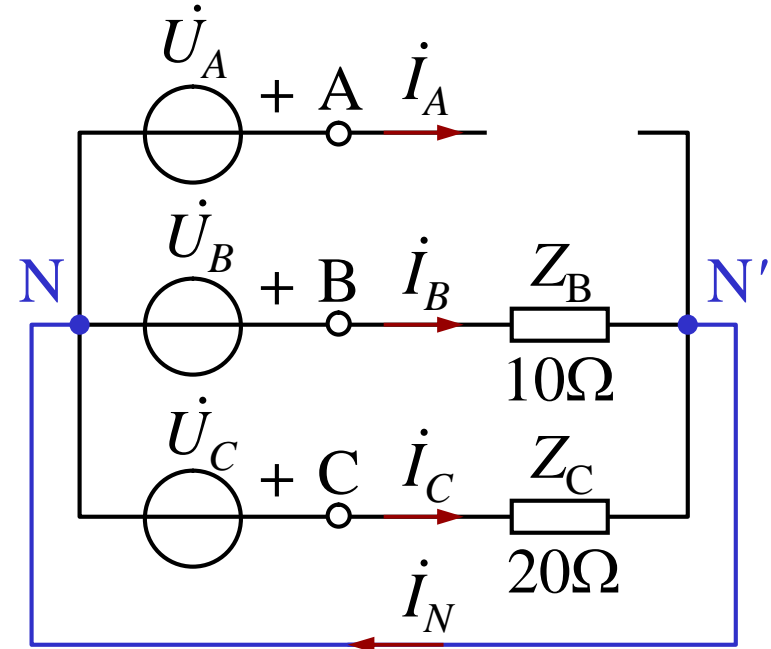

$$\begin{aligned} \dot{I}_N &= \dot{I}_A + \dot{I}_B + \dot{I}_C \\ &= \dot{I}_B + \dot{I}_C \\ &= 19.01 \angle -150.2^\circ \text{ A} \end{aligned}$$



$$\dot{U}_{AN'} = \dot{U}_A - \dot{U}_{N'N} = 144 \angle 10.8^\circ \text{ V}$$

$$\dot{U}_{BN'} = \dot{U}_B - \dot{U}_{N'N} = 250 \angle 139.1^\circ \text{ V N}$$

$$\dot{U}_{CN'} = \dot{U}_C - \dot{U}_{N'N} = 288 \angle 131^\circ \text{ V}$$

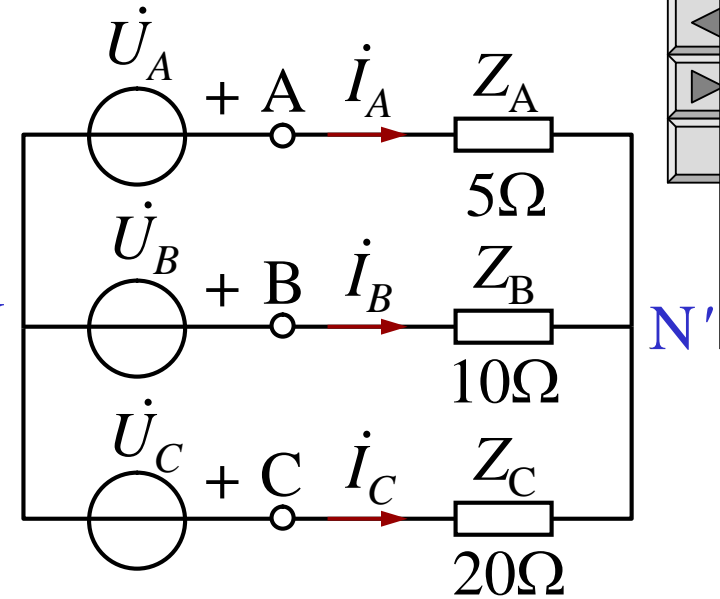

()

Y



()

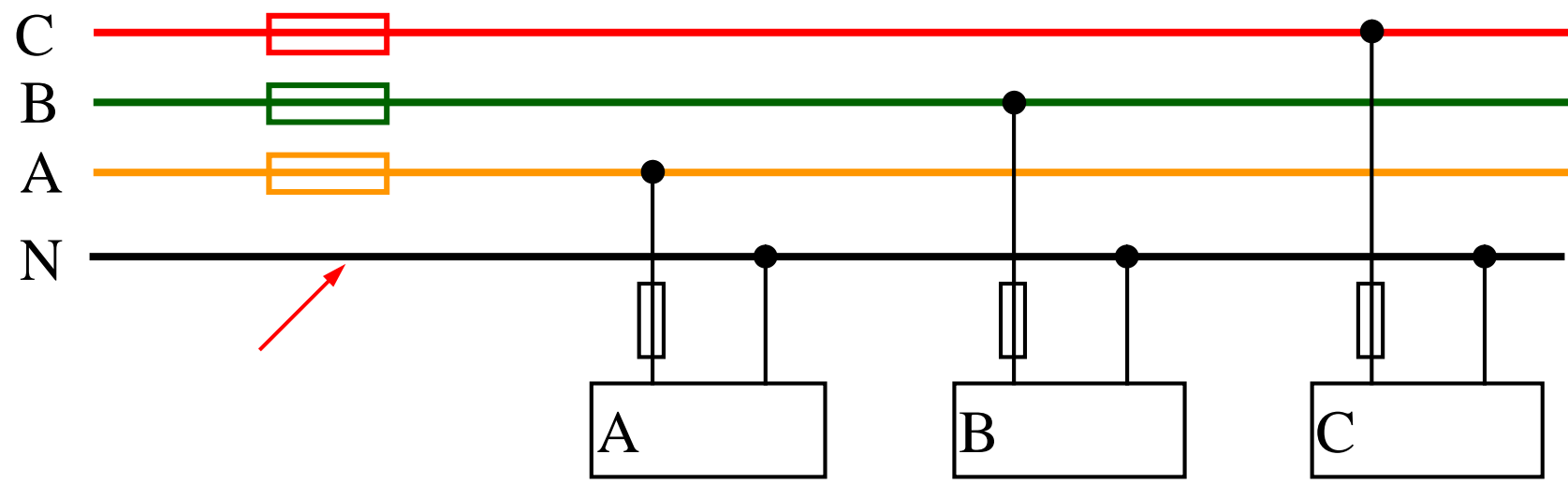
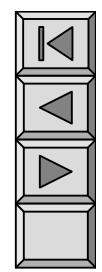
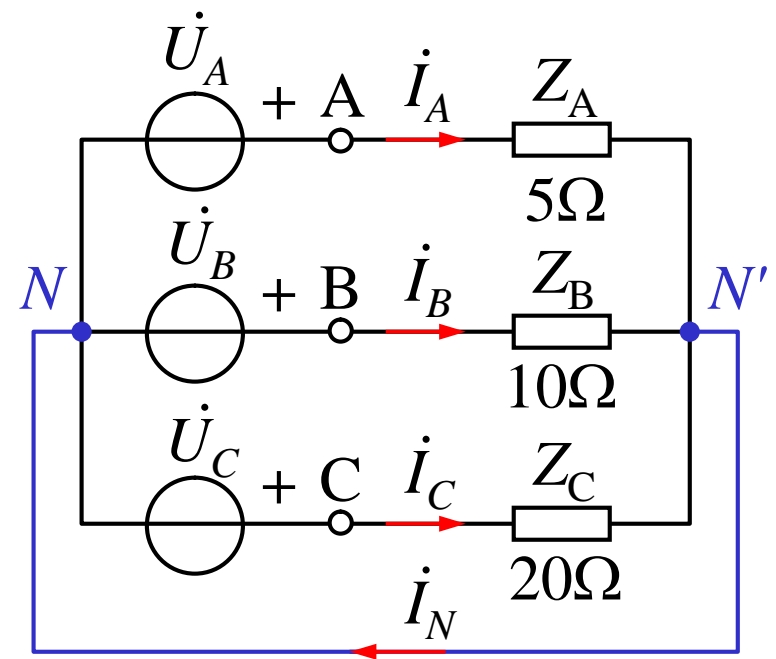



$$\dot{U}_{N'N} = \frac{j\omega C \dot{U}_A + G(\dot{U}_B + \dot{U}_C)}{j\omega C + 2G}$$

$$\dot{U}_A = U \quad 0^\circ$$

$$\dot{U}_{N'N} = 0.63U \angle 108.4^\circ \text{ V}$$

$$\begin{aligned} \dot{U}_{BN'} &= \dot{U}_{BN} - \dot{U}_{N'N} \\ &= \underline{1.5U} \angle 101.5^\circ \text{ V} \end{aligned}$$

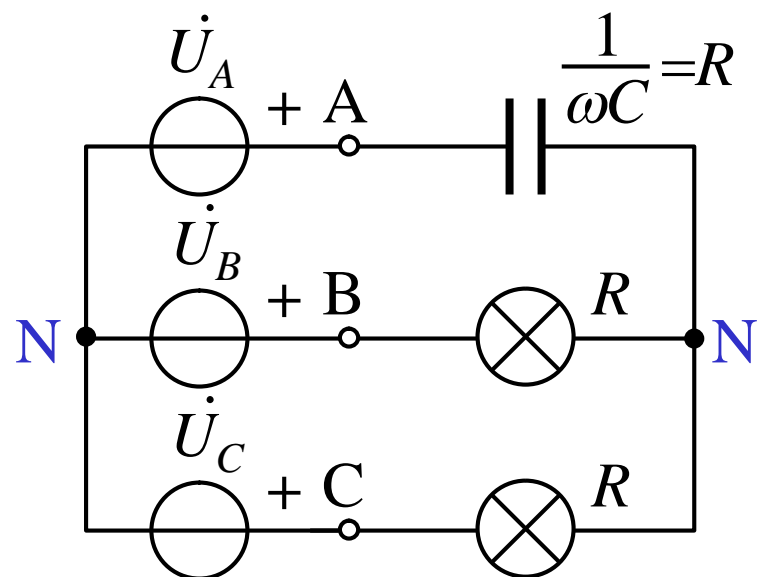

$$\begin{aligned} \dot{U}_{CN'} &= \dot{U}_{CN} - \dot{U}_{N'N} \\ &= \underline{0.4U} \angle 133.4^\circ \text{ V} \end{aligned}$$



A
B
C

§ 11-5

1. S P Q

$$\overline{S} = \overline{S}_A + \overline{S}_B + \overline{S}_C$$

$$= \dot{U}_{AN'} \dot{I}_A^* + \dot{U}_{BN'} \dot{I}_B^* + \dot{U}_{CN'} \dot{I}_C^*$$

$$= (P_A + P_B + P_C) + j(Q_A + Q_B + Q_C) = P + jQ$$

$$P = P_A + P_B + P_C$$

$$Q = Q_A + Q_B + Q_C$$

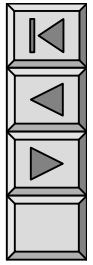
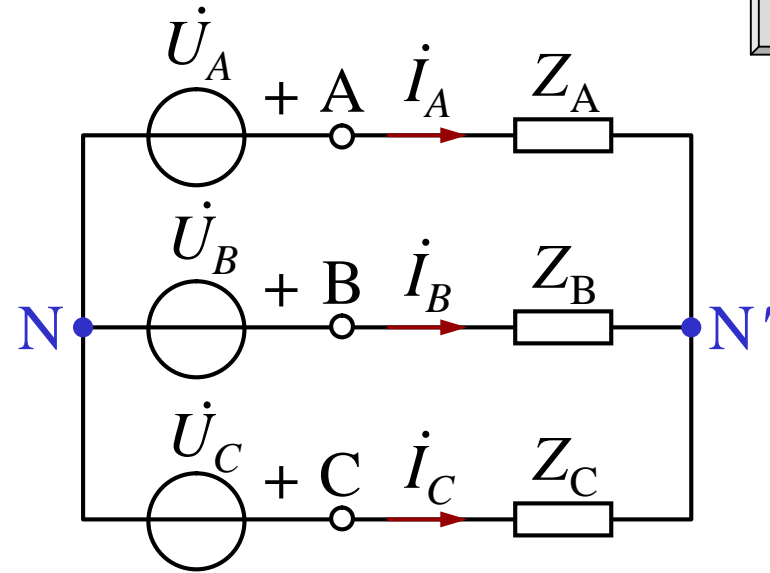



$$\bar{S} = 3 \bar{S}_A = 3 \dot{U}_{AN'} \dot{I}_A^*$$

$$P = 3U_{AN'} I_A \cos\varphi_A = 3U_{\text{ph}} I_{\text{ph}} \cos\varphi \quad \text{“ph”}$$

$$Q = 3U_{AN'} I_A \sin\varphi_A = 3U_{\text{ph}} I_{\text{ph}} \sin\varphi$$

$$\varphi (= \varphi_A = \varphi_B = \varphi_C)$$

$$\begin{array}{l} \text{Y} \\ U_{\text{ph}} = \frac{1}{\sqrt{3}} U_l \quad I_{\text{ph}} = I_l \\ U_{\text{ph}} = U_l \quad I_{\text{ph}} = \frac{1}{\sqrt{3}} I_l \end{array}$$

$$\underline{\underline{\bar{S} = \sqrt{3} U_l I_l}} \quad \underline{\underline{P = \sqrt{3} U_l I_l \cos\varphi}} \quad \underline{\underline{Q = \sqrt{3} U_l I_l \sin\varphi}}$$

φ



2.

$$p = p_A + p_B + p_C$$

$$\begin{aligned} p_A &= u_{AN} i_A = \sqrt{2} U_{\text{ph}} \cos(\omega t) \times \sqrt{2} I_{\text{ph}} \cos(\omega t - \varphi) \\ &= U_{\text{ph}} I_{\text{ph}} [\cos \varphi + \cos(2\omega t - \varphi)] \end{aligned}$$

$$\begin{aligned} p_B &= u_{BN} i_B = \sqrt{2} U_{\text{ph}} \cos(\omega t - 120^\circ) \times \sqrt{2} I_{\text{ph}} \cos(\omega t - 120^\circ - \varphi) \\ &= U_{\text{ph}} I_{\text{ph}} [\cos \varphi + \cos(2\omega t - \varphi - 240^\circ)] \end{aligned}$$

$$\begin{aligned} p_C &= u_{CN} i_C = \sqrt{2} U_{\text{ph}} \cos(\omega t + 120^\circ) \times \sqrt{2} I_{\text{ph}} \cos(\omega t + 120^\circ - \varphi) \\ &= U_{\text{ph}} I_{\text{ph}} [\cos \varphi + \cos(2\omega t - \varphi + 240^\circ)] \end{aligned}$$

$$p = p_A + p_B + p_C = 3U_{\text{ph}} I_{\text{ph}} \cos \varphi$$



3.

•

•

•

•

3

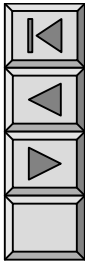

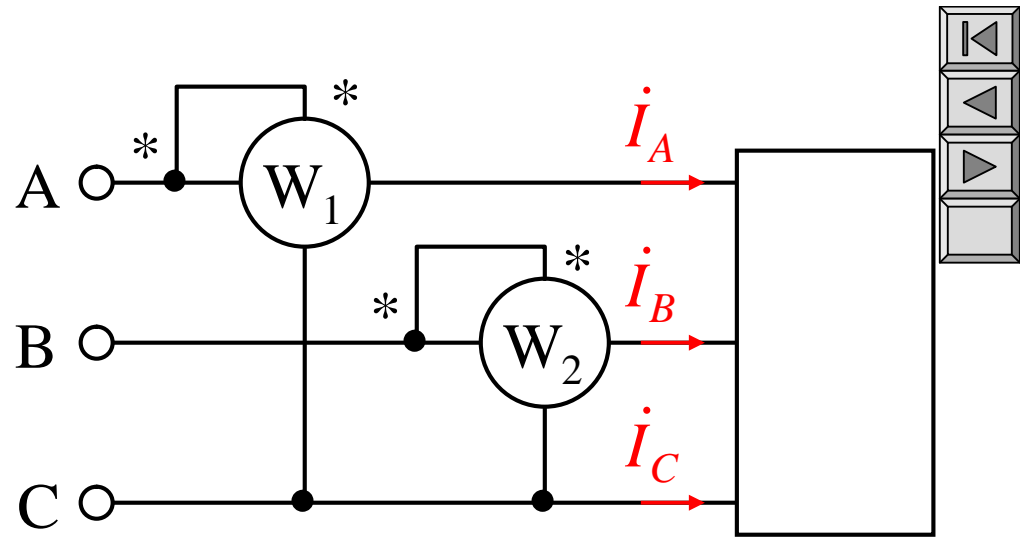

$$P_1 = \text{Re}[\dot{U}_{AC} \dot{I}_A^*] \quad P_2 = \text{Re}[\dot{U}_{BC} \dot{I}_B^*]$$

$$P_1 + P_2 = \text{Re}[\dot{U}_{AC} \dot{I}_A^* + \dot{U}_{BC} \dot{I}_B^*]$$

$$\dot{U}_{AC} = \dot{U}_A - \dot{U}_C \quad \dot{U}_{BC} = \dot{U}_B - \dot{U}_C \quad \dot{I}_A^* + \dot{I}_B^* = -\dot{I}_C^*$$

$$P_1 + P_2 = \text{Re}[\dot{U}_A \dot{I}_A^* - \dot{U}_C \dot{I}_A^* + \dot{U}_B \dot{I}_B^* - \dot{U}_C \dot{I}_B^*]$$

$$= \text{Re}[\dot{U}_A \dot{I}_A^* + \dot{U}_B \dot{I}_B^* + \dot{U}_C \dot{I}_C^*] = \text{Re}[\bar{S}]$$



1 2

Y

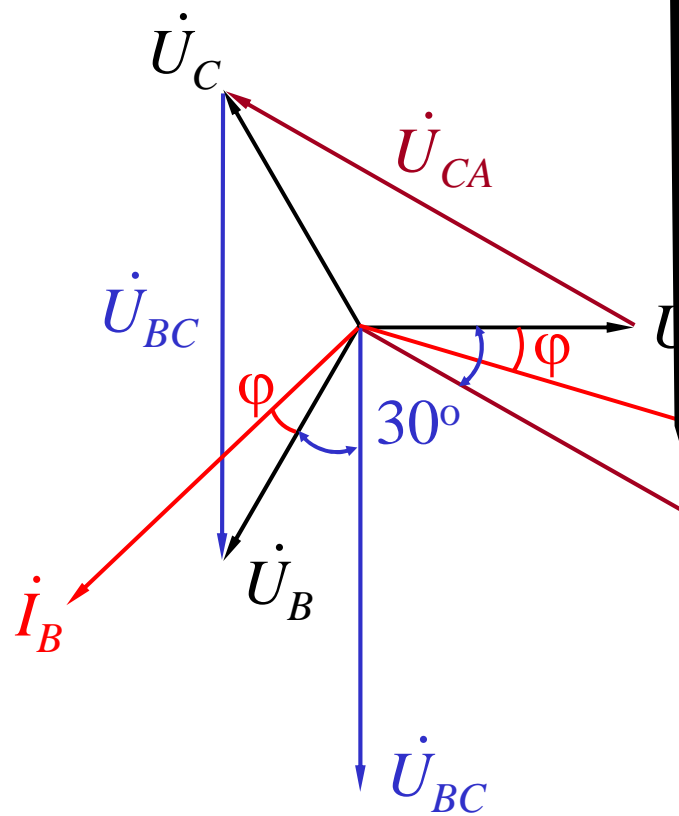

P312 12 4

$$U_l = 380\text{V} \quad P = 2.5\text{kW}$$

$$\cos\varphi = 0.866 \quad (\quad)$$

$$P = \sqrt{3} U_l I_l \cos\varphi$$

$$I_l = \frac{P}{\sqrt{3} U_l \cos\varphi} = 4.386\text{A}$$

$$\varphi = \arccos 0.866 = 30^\circ$$

$$P_1 = U_{AC} I_A \cos(30^\circ - 30^\circ) \\ = 380 \times 4.386 = 1666.68\text{W}$$

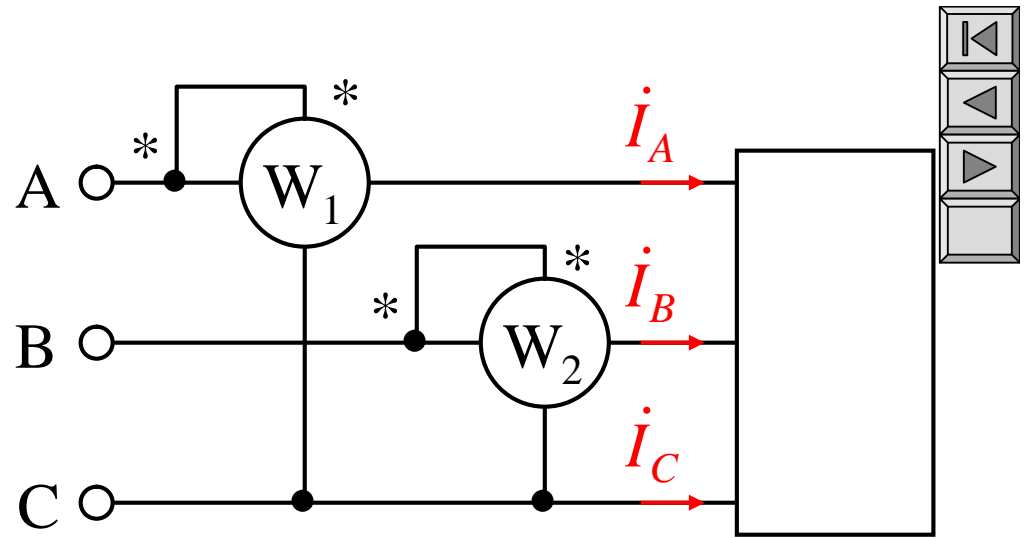

$$P_2 = U_{BC} I_B \cos(30^\circ + 30^\circ) \\ = 380 \times 4.386 \times 0.5 \\ = 833.34\text{W}$$

$$P_1 = \text{Re}[\dot{U}_{AC} \dot{I}_A^*]$$

$$P_2 = \text{Re}[\dot{U}_{BC} \dot{I}_B^*]$$

1.

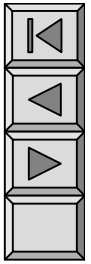
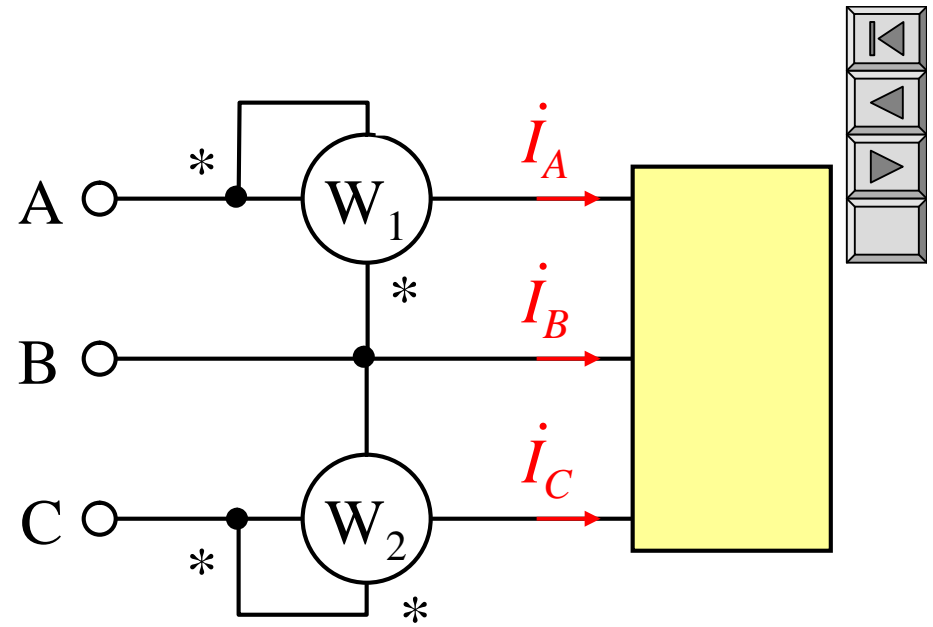

2.

$$\dot{I}_A^* + \dot{I}_B^* + \dot{I}_C^* = 0$$

$$P_1 = U_{AB} I_A \cos(30^\circ - \varphi)$$

$$P_2 = U_{CB} I_C \cos(30^\circ - \varphi)$$

$$\varphi > 60^\circ \quad P_1 < 0$$

3.

4.

$$P = \textcircled{W_2} - \textcircled{W_1}$$

P314 12 10 : $P=2.4\text{kW}$ $\cos\varphi=0.4$ ()

1.

2.

0.8

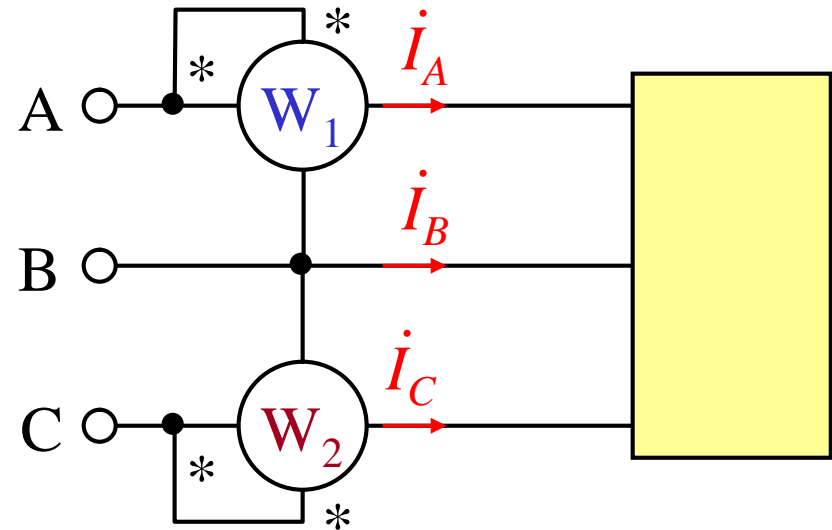

1. $\varphi = \arccos 0.4 = 66.42^\circ$

$$P_1 = U_{AB} I_A \cos(30^\circ - \varphi)$$

$$P_2 = U_{CB} I_C \cos(30^\circ + \varphi)$$

$$\frac{P_2}{P_1} = \frac{\cos(30^\circ - 66.42^\circ)}{\cos(30^\circ + 66.42^\circ)} = 7.194$$

$$P_1 + P_2 = P_1 \cdot 7.194 \Rightarrow P_1 = \frac{P}{7.194} = 0.338\text{kW}$$

$$P_1 = \frac{P}{7.194} = 0.338\text{kW}$$

$$P_2 = 7.194 \cdot (0.338) = 2.422\text{kW}$$

$$P_2 = P - P_1 = 2.4 - 0.338 = 2.062\text{kW}$$

2.

C

$$P=2.4\text{kW}$$

$$\varphi' = \arccos 0.8 = 36.87^\circ$$

$$\frac{P_2}{P_1} = \frac{\cos(30^\circ - 36.87^\circ)}{\cos(30^\circ + 36.87^\circ)} = 2.527$$

$$P_1 + P_2 = P_1 + 2.527P_1 = P = 2.4\text{kW}$$

$$P_1 = \frac{P}{+2.527} = 0.680\text{kW}$$

$$P_2 = 2.527 \cdot 0.680 = 1.719\text{kW}$$

