



- 1.
- 2.
- 3.
- 4.
- 5.
- 6.
- 7.

1.

2.

3.

4.



§ 16-1

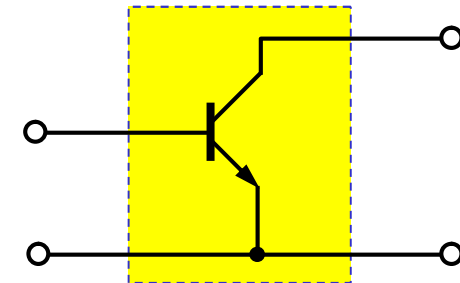
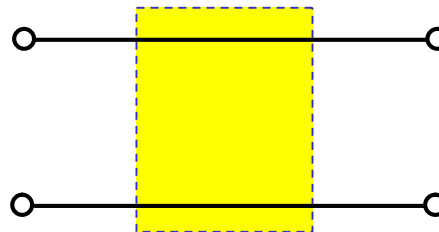
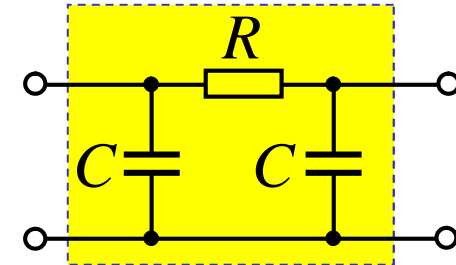
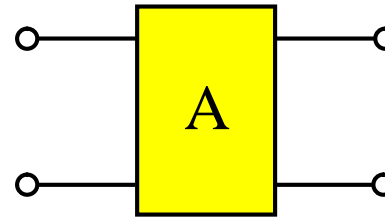
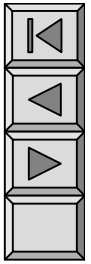

()

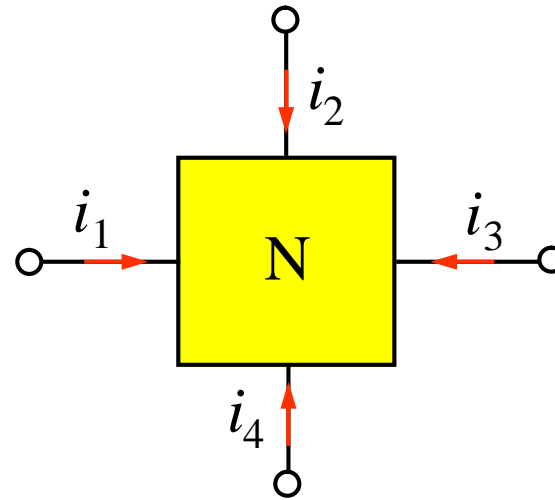
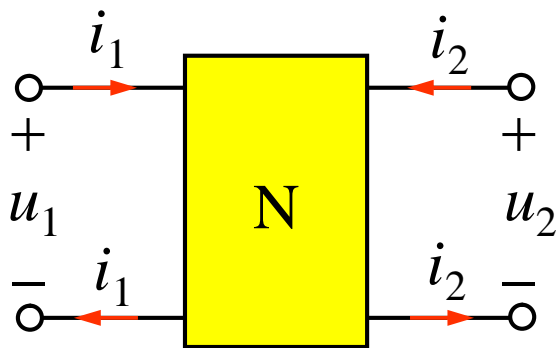
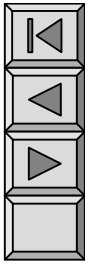



R

$$i_3 = i_1 + i \quad i_4 = i_2 - i$$

N

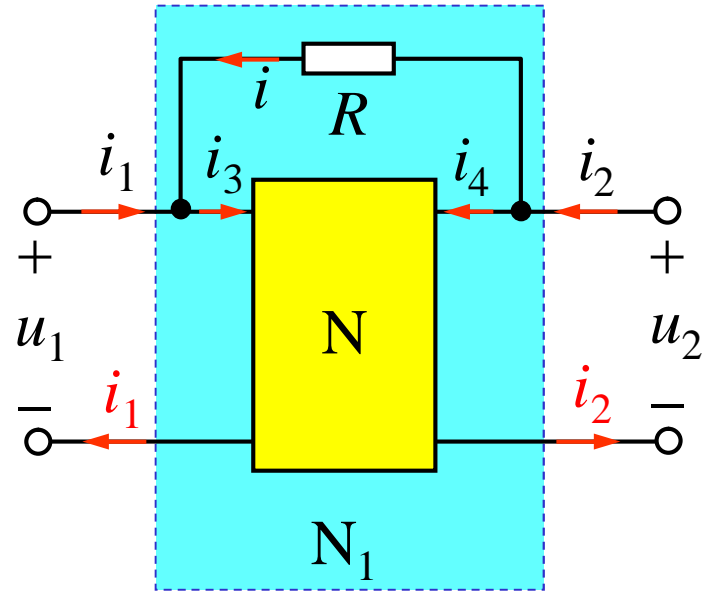

N_1

n



()

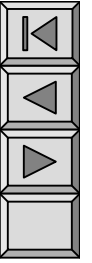

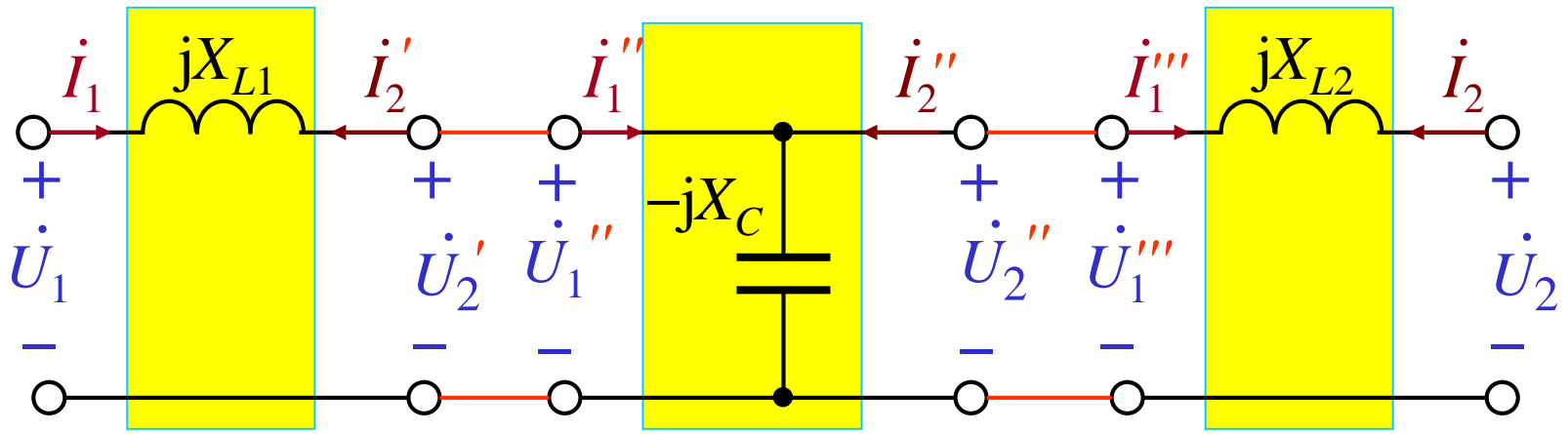
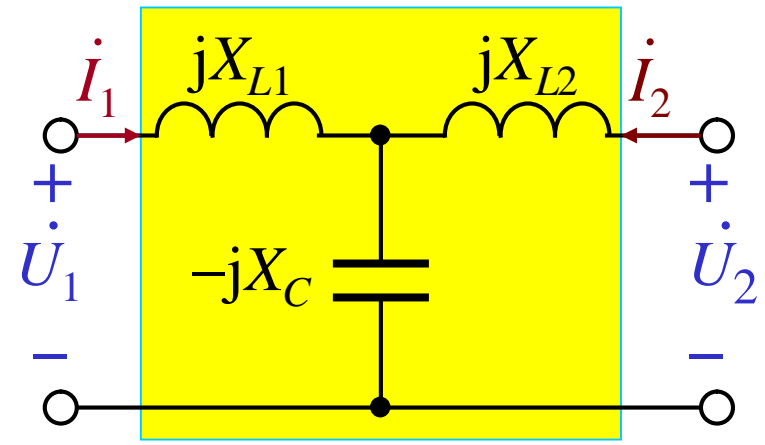

1-1'
2-2'

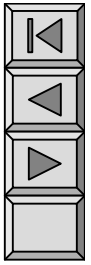
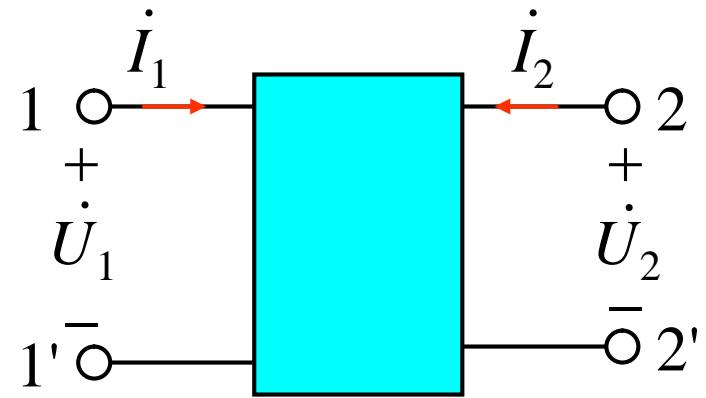

4

§ 16-2

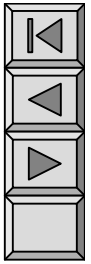

1. $Y()$ Y

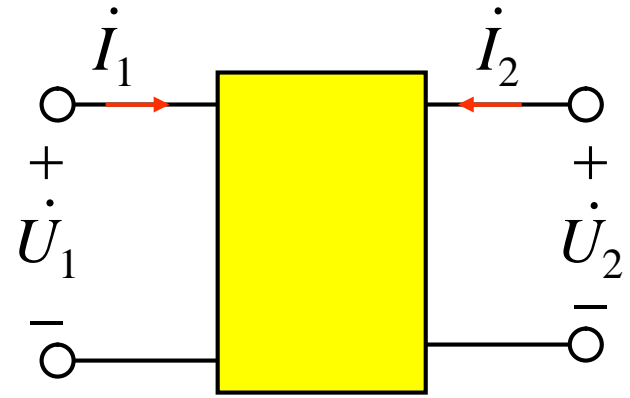

$$\left. \begin{aligned} \dot{I}_1 &= Y_{11} \dot{U}_1 + Y_{12} \dot{U}_2 \\ \dot{I}_2 &= Y_{21} \dot{U}_1 + Y_{22} \dot{U}_2 \end{aligned} \right\}$$

2. $Y()$

$$\mathbf{Y} \stackrel{\text{def}}{=} \begin{bmatrix} Y_{11} & Y_{12} \\ Y_{21} & Y_{22} \end{bmatrix}$$

$$\begin{bmatrix} \dot{I}_1 \\ \dot{I}_2 \end{bmatrix} = \begin{bmatrix} Y_{11} & Y_{12} \\ Y_{21} & Y_{22} \end{bmatrix} \begin{bmatrix} \dot{U}_1 \\ \dot{U}_2 \end{bmatrix} = \mathbf{Y} \begin{bmatrix} \dot{U}_1 \\ \dot{U}_2 \end{bmatrix} \quad \mathbf{Y}$$

3. Y

$$\left. \begin{aligned} \dot{I}_1 &= Y_{11} \dot{U}_1 + Y_{12} \dot{U}_2 \\ \dot{I}_2 &= Y_{21} \dot{U}_1 + Y_{22} \dot{U}_2 \end{aligned} \right\}$$

✓

(
)

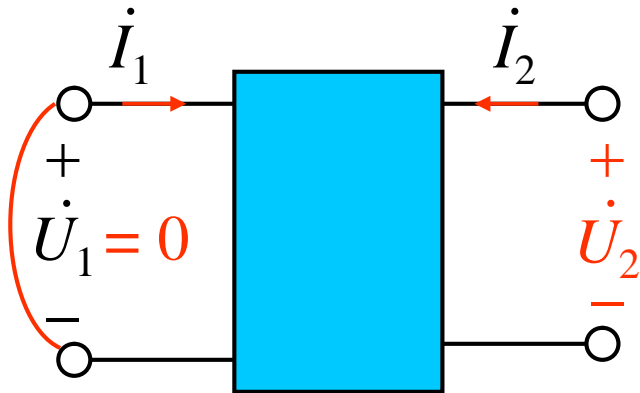

$$Y_{11} = \frac{\dot{I}_1}{\dot{U}_1} \Big|_{\dot{U}_2=0}$$

1-1'

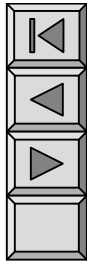

$$Y_{21} = \frac{\dot{I}_2}{\dot{U}_1} \Big|_{\dot{U}_2=0}$$

2
1 , 2

$$Y_{12} = \frac{\dot{I}_1}{\dot{U}_2} \Big|_{\dot{U}_1=0}$$

1
2 , 1

$$Y_{22} = \frac{\dot{I}_2}{\dot{U}_2} \Big|_{\dot{U}_1=0}$$

2-2'



Y

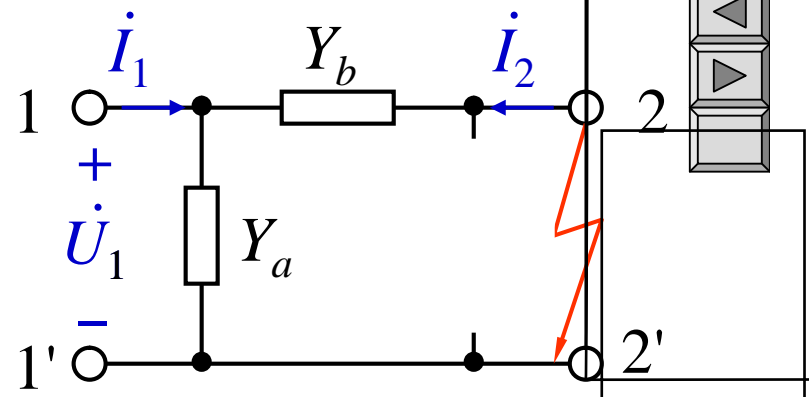

$$= Y_a + Y_b$$

$$\dot{U}_2 = 0$$

$$= -Y_b$$

$$\left. \begin{matrix} \dot{U}_1 \\ \dot{U}_2 = 0 \end{matrix} \right|$$

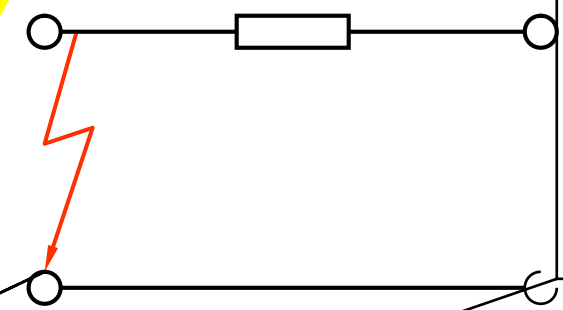
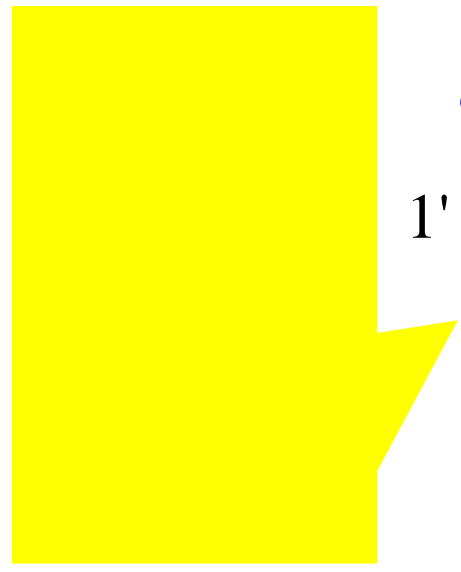

$R \quad L(M) \quad C$

$$Y_{21} = Y_{12}$$



3

Y

$$Y_{12} = Y_{21}$$
$$Y_{11} = Y_{22}$$

2

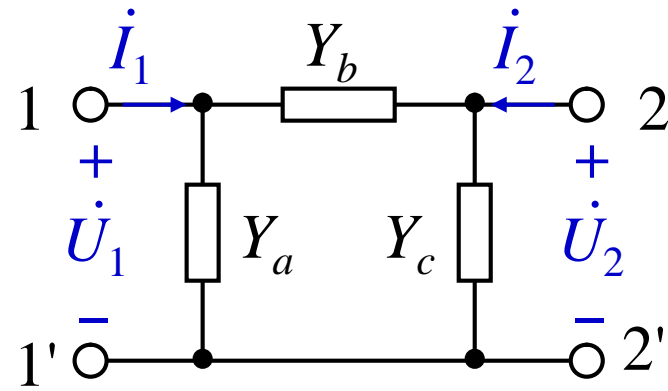

Π

$$Y_a = Y_c$$

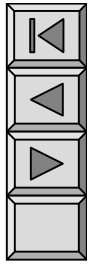

1. Z $Z()$ Z Y

➤ Y Z $Y \leftrightarrow Z$

$$\dot{I} \leftrightarrow \dot{U}$$

$$\left. \begin{aligned} \dot{U}_1 &= Z_{11}\dot{I}_1 + Z_{12}\dot{I}_2 \\ \dot{U}_2 &= Z_{21}\dot{I}_1 + Z_{22}\dot{I}_2 \end{aligned} \right\}$$

$$Z_{21} = \frac{\dot{U}_2}{\dot{I}_1} \Big|_{\dot{I}_2=0}$$

2(1)

$$Z_{12} = \frac{\dot{U}_1}{\dot{I}_2} \Big|_{\dot{I}_1=0}$$

2 1(1 2)

$$Z_{22} = \frac{\dot{U}_2}{\dot{I}_2} \Big|_{\dot{I}_1=0}$$

1-1'

2-2'

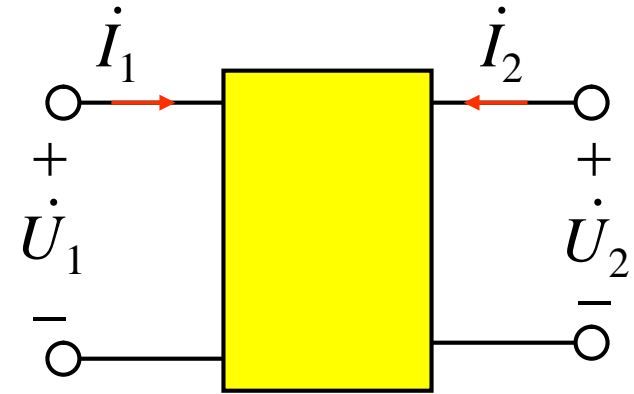

2.

$$Z_{11} = \frac{\dot{U}_1}{\dot{I}_1} \Big|_{\dot{I}_2=0}$$

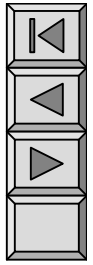



Z

$$\begin{bmatrix} \dot{U}_1 \\ \dot{U}_2 \end{bmatrix} = \begin{bmatrix} Z_{11} & Z_{12} \\ Z_{21} & Z_{22} \end{bmatrix} \begin{bmatrix} \dot{I}_1 \\ \dot{I}_2 \end{bmatrix} = \mathbf{Z} \begin{bmatrix} \dot{I}_1 \\ \dot{I}_2 \end{bmatrix}$$

Y **Z**

Z()

$$\mathbf{Z} \stackrel{\text{def}}{=} \begin{bmatrix} Z_{11} & Z_{12} \\ Z_{21} & Z_{22} \end{bmatrix}$$

•

$$Z_{21} = Z_{12}$$

$$\mathbf{Z} = \mathbf{Y}^{-1} \quad \mathbf{Y} = \mathbf{Z}^{-1}$$

$$\begin{bmatrix} Z_{11} & Z_{12} \\ Z_{21} & Z_{22} \end{bmatrix} = \frac{1}{\Delta_Y} \begin{bmatrix} Y_{22} & -Y_{12} \\ -Y_{21} & Y_{11} \end{bmatrix}$$

$$\Delta_Y = Y_{11} Y_{22} - Y_{12} Y_{21}$$

3. **Y**

$$\begin{bmatrix} \dot{I}_1 \\ \dot{I}_2 \end{bmatrix} = \begin{bmatrix} Y_{11} & Y_{12} \\ Y_{21} & Y_{22} \end{bmatrix} \begin{bmatrix} \dot{U}_1 \\ \dot{U}_2 \end{bmatrix} = \mathbf{Y} \begin{bmatrix} \dot{U}_1 \\ \dot{U}_2 \end{bmatrix}$$

4. **Z**



P438 16-2 (a) Z

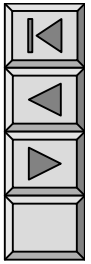

$$Z_{11} = Z_{22} = \frac{(1+1) \times 1}{(1+1)+1} + 1$$

$$\dot{U}_2 = Z_{21} \dot{I}_1 =$$

$$Z_{21} = \left. \frac{\dot{U}_2}{\dot{I}_1} \right|_{\dot{I}_2=0}$$

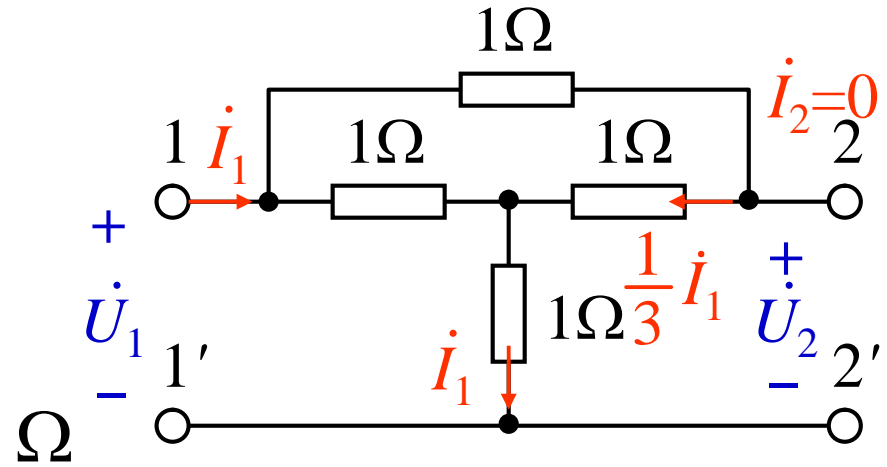

$$\mathbf{Z} = \begin{bmatrix} & \\ & \end{bmatrix} \Omega$$

$$\begin{bmatrix} Y_{11} & Y_{12} \\ Y_{21} & Y_{22} \end{bmatrix} = \frac{1}{\Delta_Z} \begin{bmatrix} Z_{22} & -Z \\ & \end{bmatrix}$$

P423 16-2

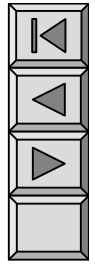
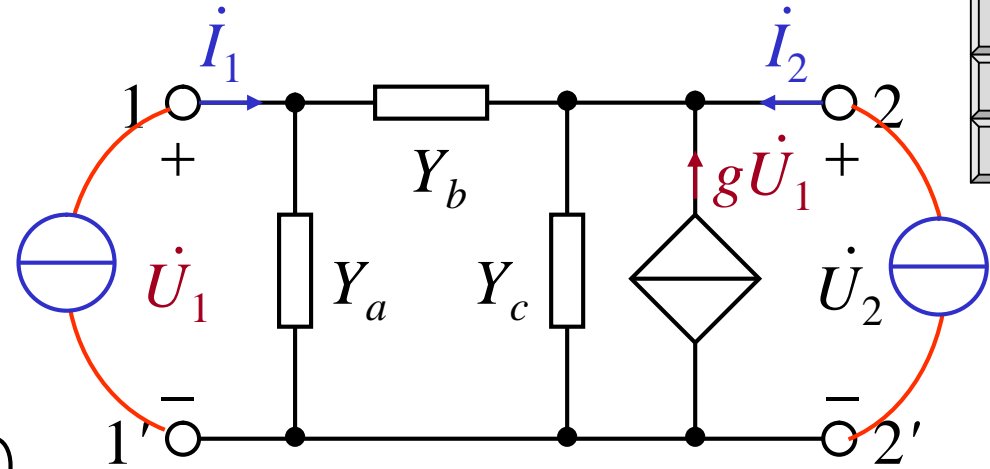

$$\dot{I}_1 = (Y_a + Y_b)\dot{U}_1 - Y_b\dot{U}_2$$

$$\dot{I}_2 = -(Y_b + g)\dot{U}_1 + (Y_b + Y_c)\dot{U}_2$$

4 Y

$$\begin{bmatrix} \dot{I}_1 \\ \dot{I}_2 \end{bmatrix} = \begin{bmatrix} Y_a + Y_b & -Y_b \\ -(Y_b + g) & Y_b + Y_c \end{bmatrix} \begin{bmatrix} \dot{U}_1 \\ \dot{U}_2 \end{bmatrix}$$

$$\mathbf{Y} = \begin{bmatrix} Y_{11} & Y_{12} \\ Y_{21} & Y_{22} \end{bmatrix} = \begin{bmatrix} Y_a + Y_b & -Y_b \\ -(Y_b + g) & Y_b + Y_c \end{bmatrix} \quad (1)$$

(2)

2010 3 3

Y_{12} Y_{21}

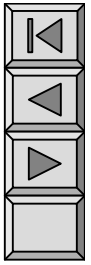

1. ()

2. ()

3. (P378 16-1)



$T()$

$Y \quad Z$

$$Z=Y^{-1} \quad Y=Z^{-1}。$$

(1)

()

(2)

$Y \quad Z$

(3)

$Y \quad Z$

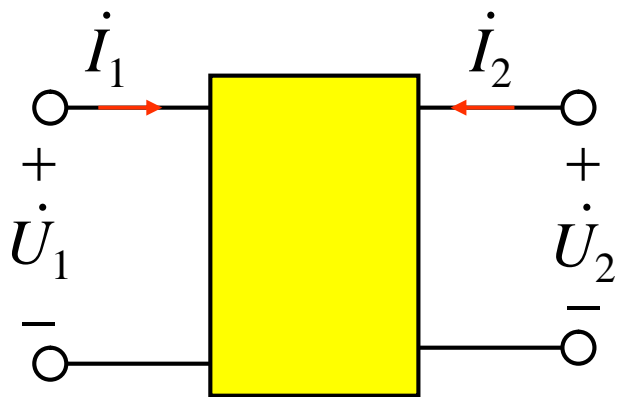

$$\left. \begin{aligned} i_1 &= Y_{11} \dot{U}_1 + Y_{12} \dot{U}_2 \\ i_2 &= Y_{21} \dot{U}_1 + Y_{22} \dot{U}_2 \end{aligned} \right\}$$

Y

$$\dot{U}_1 = -\frac{Y_{22}}{Y_{21}} \dot{U}_2 + \frac{1}{Y_{21}} i_2$$

$\dot{U}_1 \qquad \qquad \qquad 1$

$$\underline{\underline{i_1 = \left(Y_{12} - \frac{Y_{11} Y_{22}}{Y_{21}} \right) \dot{U}_2 + \frac{Y_{11}}{Y_{21}} i_2}}$$

$$\left. \begin{aligned} \dot{U}_1 &= A \dot{U}_2 - B i_2 \\ i_1 &= C \dot{U}_2 - D i_2 \end{aligned} \right\}$$

- T
- $A \quad B \quad C \quad D \quad T(\quad)$
- $A(\quad)$
- $(A_{11} \quad A_{12} \quad A_{21} \quad A_{22})$
- Y

T

T



$$\begin{bmatrix} \dot{U}_1 \\ \dot{I}_1 \end{bmatrix} = \underbrace{\begin{bmatrix} A & B \\ C & D \end{bmatrix}}_T \begin{bmatrix} \dot{U}_2 \\ -\dot{I}_2 \end{bmatrix}$$

T

$$C = \left. \frac{\dot{I}_1}{\dot{U}_2} \right|_{\dot{I}_2=0}$$

$$D = \left. \frac{\dot{I}_1}{-\dot{I}_2} \right|_{\dot{U}_2=0}$$

1

$$A = \left. \frac{\dot{U}_1}{\dot{U}_2} \right|_{\dot{I}_2=0}$$

•

•

•

1

3

T

$$B = \left. \frac{\dot{U}_1}{-\dot{I}_2} \right|_{\dot{U}_2=0}$$

$$AD - BC = 1 \quad (\quad B=C \quad)$$

$$A=D$$

P438 16-3 (c)

T

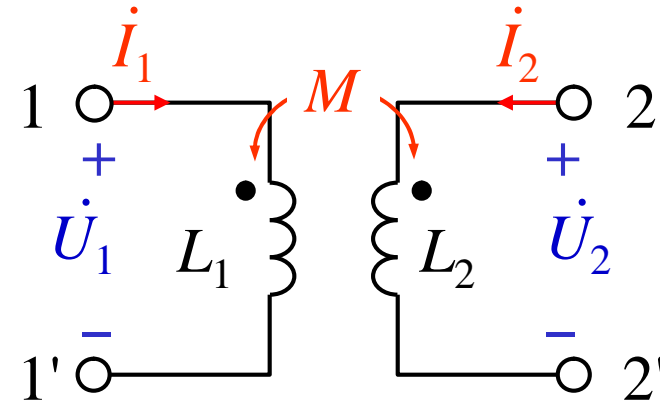

$$\left. \begin{aligned} \dot{U}_1 &= j\omega L_1 \dot{I}_1 + j\omega M \dot{I}_2 \\ \dot{U}_2 &= j\omega M \dot{I}_1 + j\omega L_2 \dot{I}_2 \end{aligned} \right\}$$

$$\dot{I}_1 = \frac{1}{j\omega M} \dot{U}_2 + \frac{L_2}{M} (-\dot{I}_2)$$

$$T = \begin{bmatrix} \frac{L_1}{M} & \frac{j\omega L_1 L_2}{M} - j\omega M \\ \frac{1}{j\omega M} & \frac{L_2}{M} \end{bmatrix}$$

1

$$\dot{U}_1 = j\omega L_1 \left[\frac{1}{j\omega M} \dot{U}_2 - \frac{L_2}{M} \dot{I}_2 \right] + j\omega M \dot{I}_2$$

$$\dot{U}_1 = \frac{L_1}{M} \dot{U}_2 + \left[\frac{j\omega L_1 L_2}{M} - j\omega M \right] (-\dot{I}_2)$$

- $AB - CD = 1$

3

- $L_1 = L_2$

- $A = D$

$$\left. \begin{aligned} \dot{U}_1 &= n \dot{U}_2 \\ \dot{I}_1 &= -\frac{1}{n} \dot{I}_2 \end{aligned} \right\}$$

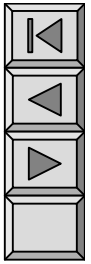
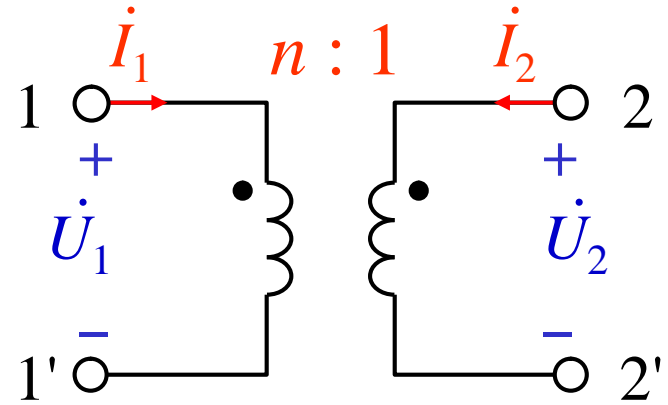

$$\begin{bmatrix} \dot{U}_1 \\ \dot{I}_1 \end{bmatrix} = \begin{bmatrix} n & 0 \\ 0 & \frac{1}{n} \end{bmatrix} \begin{bmatrix} \dot{U}_2 \\ -\dot{I}_2 \end{bmatrix}$$

T

$$T = \begin{bmatrix} n & 0 \\ 0 & \frac{1}{n} \end{bmatrix}$$

$$Z = \begin{bmatrix} \frac{A}{C} & \frac{\Delta_T}{C} \\ \frac{1}{C} & \frac{D}{C} \end{bmatrix} \quad \begin{matrix} B & C \\ 0 & \end{matrix}$$

$$Y = \begin{bmatrix} \frac{D}{B} & -\frac{\Delta_T}{B} \\ -\frac{1}{B} & \frac{A}{B} \end{bmatrix} \quad \begin{matrix} Y & Z \\ & \end{matrix}$$

$H(\quad)$

$$\left. \begin{aligned} \dot{U}_1 &= H_{11}\dot{I}_1 + H_{12}\dot{U}_2 \\ \dot{I}_2 &= H_{21}\dot{I}_1 + H_{22}\dot{U}_2 \end{aligned} \right\}$$

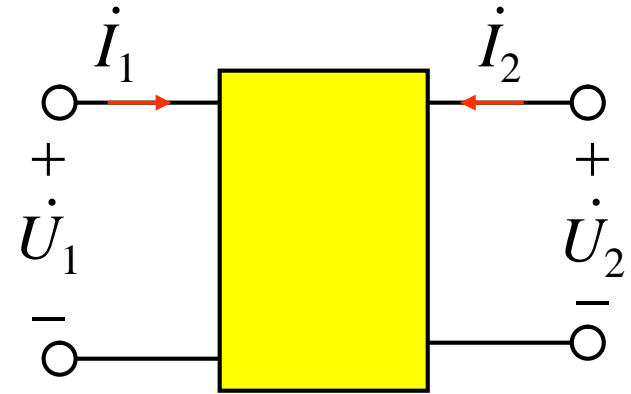

1. H

$$H_{11} = \frac{\dot{U}_1}{\dot{I}_1} \Big|_{\dot{U}_2=0}$$

$$H_{21} = \frac{\dot{I}_2}{\dot{I}_1} \Big|_{\dot{U}_2=0} \quad (\quad)$$

$$H_{11} = 1/Y_{11}^\circ$$

$$H_{22} = \frac{\dot{I}_2}{\dot{U}_2} \Big|_{\dot{I}_1=0}$$

$$H_{22} = 1/Z_{22}^\circ$$

$$H_{12} = \frac{\dot{U}_1}{\dot{U}_2} \Big|_{\dot{I}_1=0}$$

2. H

$$\begin{bmatrix} \dot{U}_1 \\ \dot{I}_2 \end{bmatrix} = \underbrace{\begin{bmatrix} H_{11} & H_{12} \\ H_{21} & H_{22} \end{bmatrix}}_H \begin{bmatrix} \dot{I}_1 \\ \dot{U}_2 \end{bmatrix}$$

Π H

$$H_{11} = \frac{1}{Y_{11}} = \frac{1}{Y_a + Y_b}$$

H_{12}

$$\dot{U}_1 = \frac{\frac{1}{Y_a}}{\frac{1}{Y_a} + \frac{1}{Y_b}} \dot{U}_2$$

H_{21}

$$H_{22} = Y_c + \frac{1}{\frac{1}{Y_a} + \frac{1}{Y_b}}$$

$$\dot{I}_2 = - \frac{\frac{1}{Y_a}}{\frac{1}{Y_a} + \frac{1}{Y_b}} \dot{I}_1$$

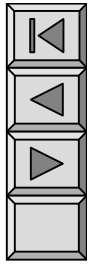
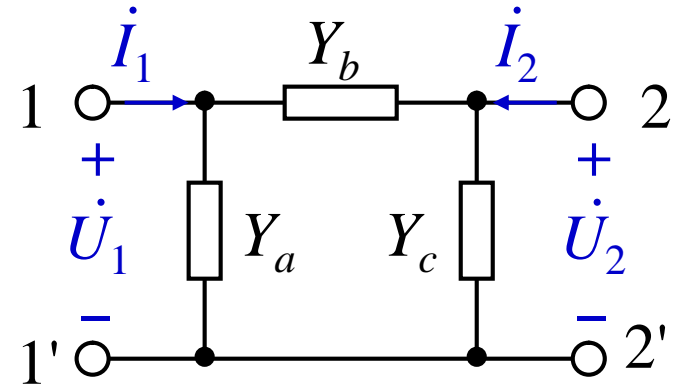



$$H \quad 3 \quad H_{21} = -H_{12}$$

$$Y_{11} = Y_{22} \quad Z_{11} = Z_{22}$$

$$H_{11}H_{22} - H_{12}H_{21} = 1$$

H

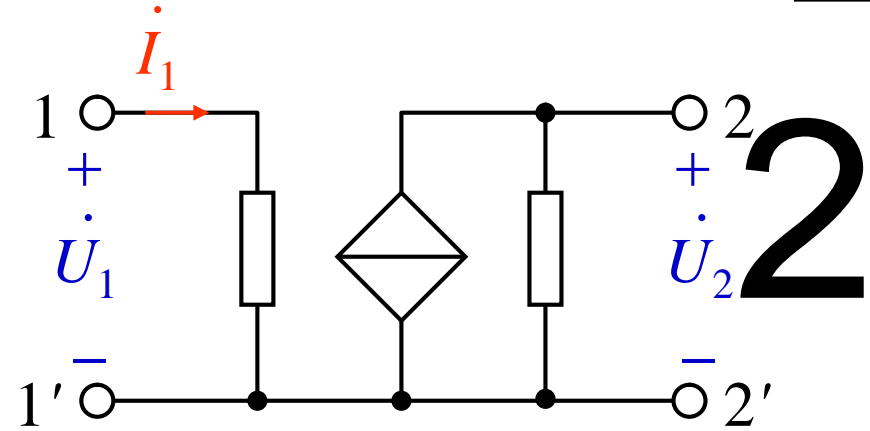

§ 16-3

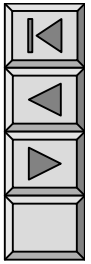

•

Z_{eq}



•

3

()

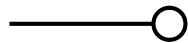

•

T(Π)

1 Z

T

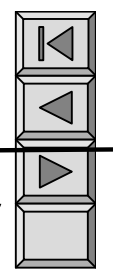
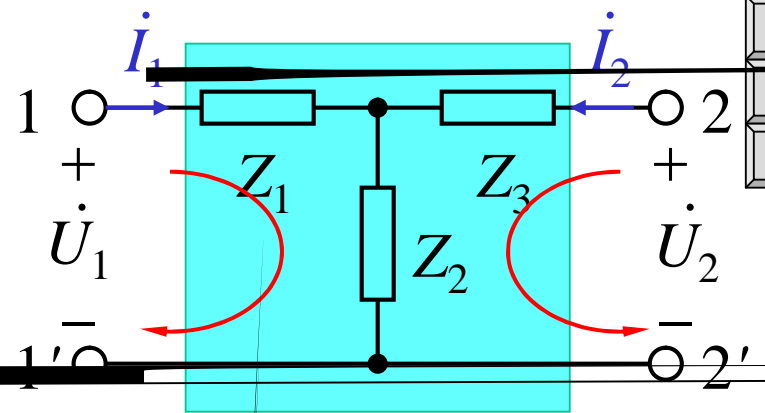

~~$\dot{U}_1 = (Z_1 + Z_2) i_1$~~

Z_1 Z_2 Z_3 T

2.

Y

Π

Y

$$\left. \begin{aligned} \dot{I}_1 &= (Y_1 + Y_2) \dot{U}_1 - Y_2 \dot{U}_2 \\ \dot{I}_2 &= -Y_2 \dot{U}_1 + (Y_2 + Y_3) \dot{U}_2 \end{aligned} \right\}$$

Y

$$\left. \begin{aligned} \dot{I}_1 &= Y_{11} \dot{U}_1 + Y_{12} \dot{U}_2 \\ \dot{I}_2 &= Y_{21} \dot{U}_1 + Y_{22} \dot{U}_2 \end{aligned} \right\}$$

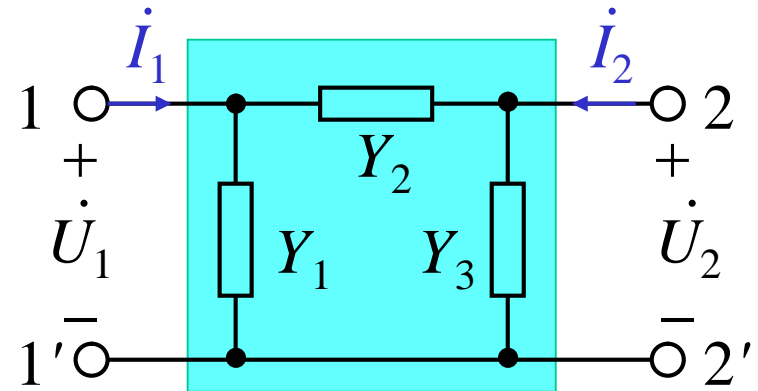

$$\underline{Y_2 = -Y_{12} = -Y_{21}}$$

$$Y_{11} = Y_1 - Y_{12} \longrightarrow \underline{Y_1 = Y_{11} + Y_{12}}$$

$$Y_{22} = Y_2 + Y_3 \longrightarrow Y_3 = Y_{22} + Y_{12}$$

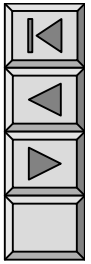



$$\left. \begin{array}{l} \dot{U}_1 = A \dot{U}_2 - B \dot{I}_2 \\ \dot{I}_1 = C \dot{U}_2 - D \dot{I}_2 \end{array} \right\} \begin{array}{l} T \\ 2 \end{array}$$

$$\dot{U}_2 = \frac{1}{C} \dot{I}_1 + \frac{D}{C} \dot{I}_2$$

$$\dot{U}_1 = \frac{A}{C} \dot{I}_1 + \left[\frac{AD}{C} - B \right] \dot{I}_2$$

$$AD - BC = 1$$

$$\left. \begin{array}{l} \dot{U}_1 = \frac{A}{C} \dot{I}_1 + \frac{1}{C} \dot{I}_2 \\ \dot{U}_2 = \frac{1}{C} \dot{I}_1 + \frac{D}{C} \dot{I}_2 \end{array} \right\} \begin{array}{l} T \\ Z \end{array}$$

$$\begin{array}{l} Z \\ T \\ Z \end{array}$$

$$Z_1 = Z_{11} - Z_{12} = \frac{A-1}{C}$$

$$Z_2 = Z_{12} = Z_{21} = \frac{1}{C}$$

$$Z_3 = Z_{22} - Z_{12} = \frac{D-1}{C}$$

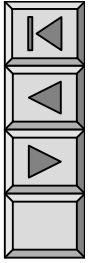
Π $Y_1 \quad Y_2 \quad Y_3 \quad T$ 

4.

(1)T

$$\left. \begin{aligned} \dot{U}_1 &= Z_{11} \dot{I}_1 + Z_{12} \dot{I}_2 \\ \dot{U}_2 &= Z_{21} \dot{I}_1 + Z_{22} \dot{I}_2 \end{aligned} \right\}$$

$$Z_{12} \quad Z_{21}$$

2

$$\dot{U}_2 = Z_{12} \dot{I}_1 + Z_{22} \dot{I}_2$$

(2)Π

$$Y_{12} \quad Y_{21}$$

$$\left. \begin{aligned} \dot{I}_1 &= Y_{11} \dot{U}_1 + Y_{12} \dot{U}_2 \\ \dot{I}_2 &= Y_{12} \dot{U}_1 + Y_{22} \dot{U}_2 + \underline{(Y_{21} - Y_{12}) \dot{U}_1} \end{aligned} \right\}$$

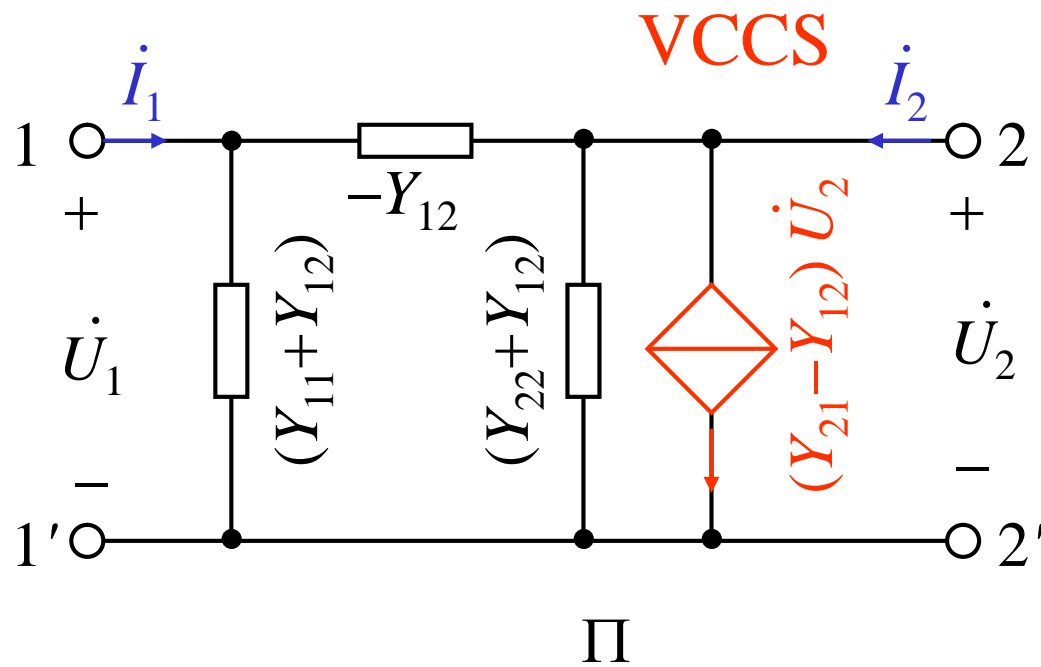

P440

16-10(b)

$$\mathbf{Y} = \begin{bmatrix} 5 & -2 \\ 0 & 3 \end{bmatrix}$$

Π

$$Y_{11} = 5\text{S} \quad Y_{22} = 3\text{S}$$

$$Y_{12} = -2\text{S} \quad Y_{21} = 0$$

$$(Y_{21} - Y_{12}) = 2\text{S}$$

$$Y_1 = (Y_{11} + Y_{12}) = 3\text{S}$$

$$Y_2 = -Y_{12} = 2\text{S}$$

$$Y_3 = (Y_{22} + Y_{12}) = 1\text{S}$$

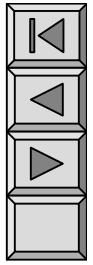

§ 16-4

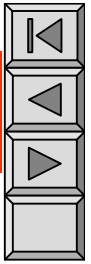

-

- 14

-

- 1.

2.

(1)

$$U_1(s) = Z_{11}(s)I_1(s)$$

$$U_2(s) = Z_{21}(s)I_1(s)$$

$$I_2(s) = 0,$$

$$\frac{U_2(s)}{U_1(s)} = \frac{Z_{21}(s)}{Z_{11}(s)}$$

Y

$$I_1(s) = Y_{11}(s)U_1(s) + Y_{12}(s)U_2(s)$$

$$I_2(s) = Y_{21}(s)U_1(s) + Y_{22}(s)U_2(s) = 0 \rightarrow \frac{U_2(s)}{U_1(s)} = -\frac{Y_{21}(s)}{Y_{22}(s)}$$

$$I_2(s) = 0$$

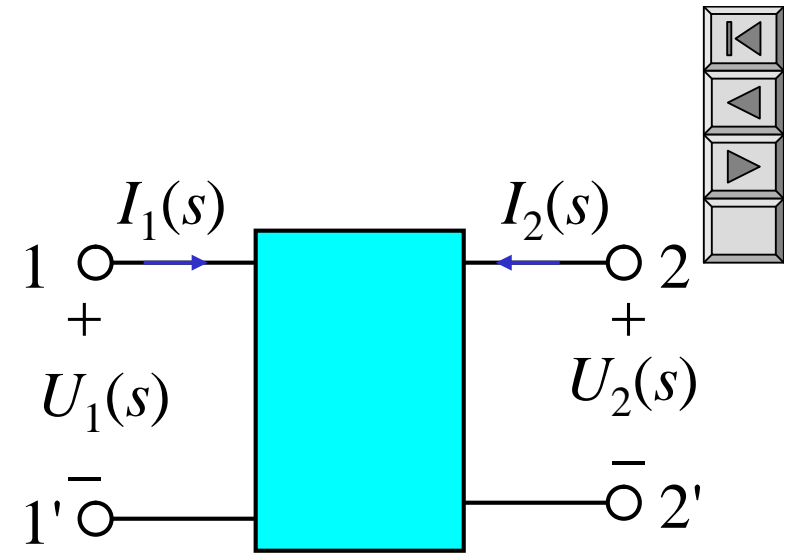

(2)

Z_{22}

$$U_2(s) = Z_{21}(s)I_1(s) + Z_{22}(s)I_2(s)$$

$$U_2(s) = 0$$

Z

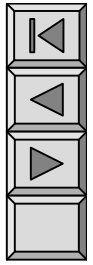
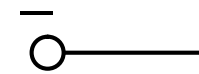
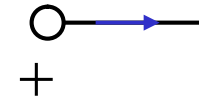

(3)

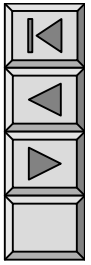

(4)



•

Z_L

Z_S

•

(1) $Z_S \quad Z_L$

(2) $Z_S \quad Z_L$



VCR

1.

✓ Y

$$I_2(s) = Y_{21}(s)U_1(s) + Y_{22}(s)U_2(s)$$

✓ VCR:

$$U_2(s) = -R I_2(s)$$

$U_2(s)$:

$$I_2(s) = Y_{21}(s)U_1(s) - Y_{22}(s)R I_2(s)$$

✓

$$U_2(s) = Z_{21}(s)I_1(s) - Z_{22}(s)\frac{U_2(s)}{R}$$

$$\frac{I_2(s)}{U_1(s)} = \frac{Y_{21}(s)}{1 + Y_{22}(s)R}$$

Z

$$U_2(s) = Z_{21}(s)I_1(s) + Z_{22}(s)I_2(s)$$

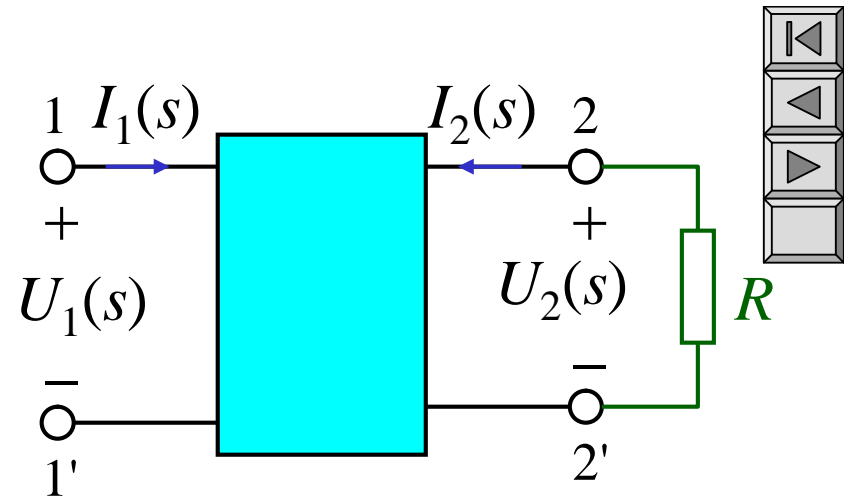

VCR

$U_2(s)$:

$$\frac{U_2(s)}{I_1(s)} = \frac{Z_{21}(s)}{R + Z_{22}(s)}$$

$$I_2(s) = Y_{21}(s) U_1(s) + Y_{22}(s) U_2(s)$$

$$U_1(s) = Z_{11}(s) I_1(s) + Z_{12}(s) I_2(s)$$

$$U_2(s) = -R I_2(s)$$

$$U_2(s) \quad U_1(s)$$

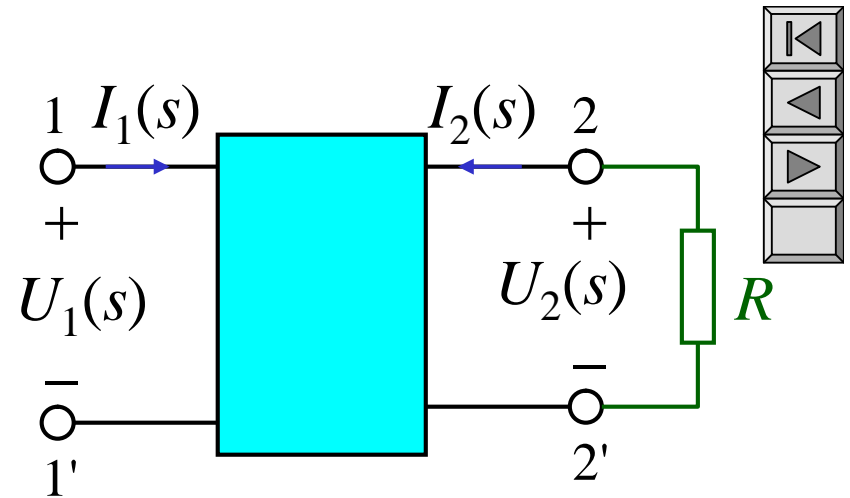

$$\frac{I_2(s)}{I_1(s)} = \frac{Y_{21}(s) Z_{11}(s)}{1 + Y_{22}(s) R - Z_{12}(s) Y_{21}(s)}$$

$$\frac{I_2(s)}{I_1(s)}$$

$$\frac{U_2(s)}{U_1(s)} = \frac{Z_{21}(s) Y_{11}(s)}{1 + Z_{22}(s) \frac{1}{R} - Z_{21}(s) Y_{12}(s)}$$

2.

$U_1(s)$

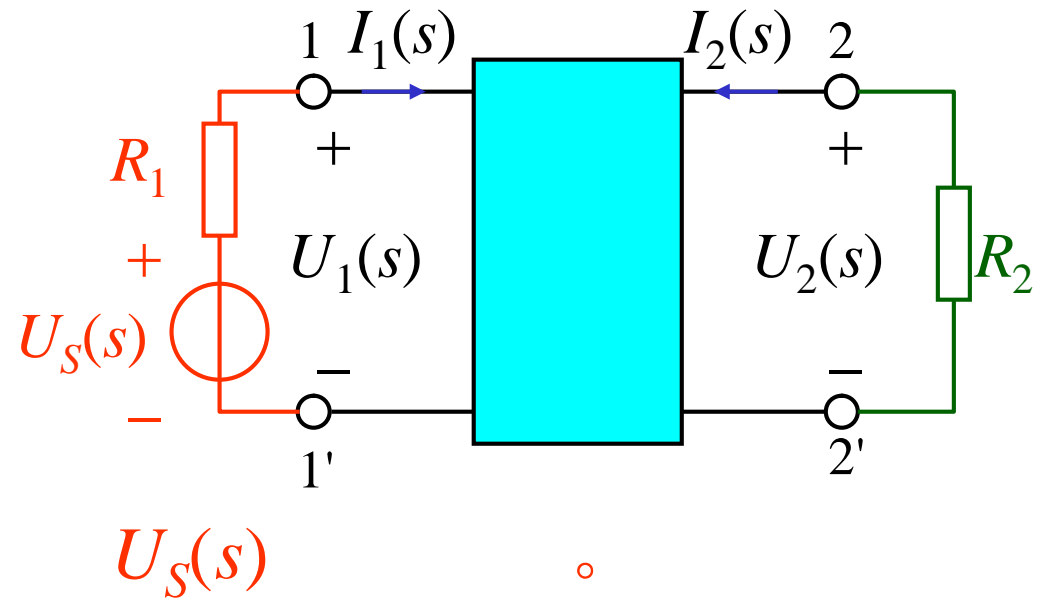

$$U_1(s) = U_S(s) - R_1 I_1(s)$$

$$U_2(s) = -R_2 I_2(s)$$

Z

$$U_S(s) - R_1 I_1(s) = Z_{11}(s)I_1(s) + Z_{12}(s) I_2(s)$$

$$-R_2 I_2(s) = Z_{21}(s)I_1(s) + Z_{22}(s) I_2(s)$$

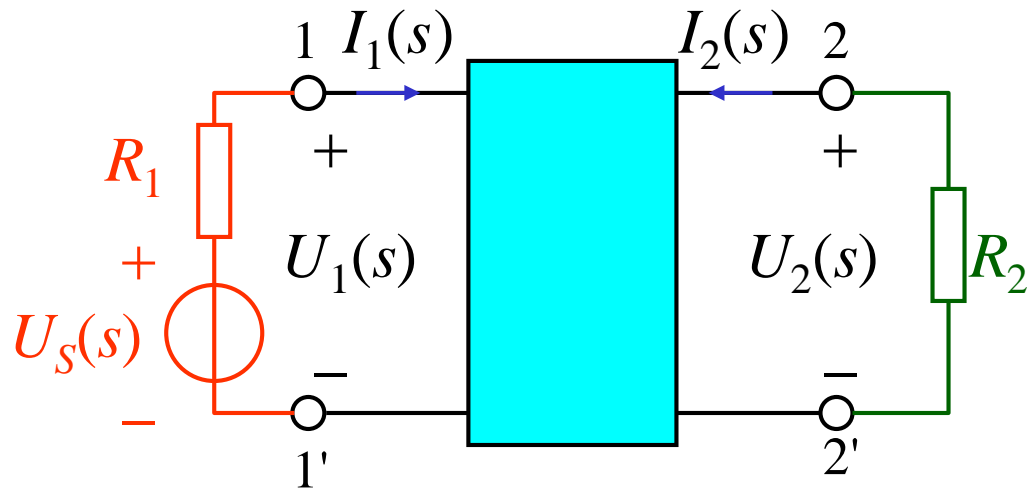

$$\left. \begin{aligned}
 U_S(s) - R_1 I_1(s) &= Z_{11}(s) I_1(s) + Z_{12}(s) I_2(s) \\
 -R_2 I_2(s) &= Z_{21}(s) I_1(s) + Z_{22}(s) I_2(s) \\
 U_S(s) &= [Z_{11}(s) + R_1] I_1(s) + Z_{12}(s) I_2(s)
 \end{aligned} \right\} \begin{matrix} I_1(s) \\ I_2(s) \end{matrix} \circ$$

$$\frac{U_2(s)}{U_S(s)} = \frac{-R_2 I_2(s)}{U_S(s)} = \frac{-Z_{21}(s) R_2}{[R_1 + Z_{11}(s)][R_2 + Z_{22}(s)] - Z_{12}(s) Z_{21}(s)}$$

§ 16-5

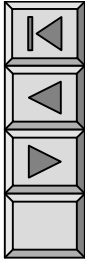

✓

✓

3

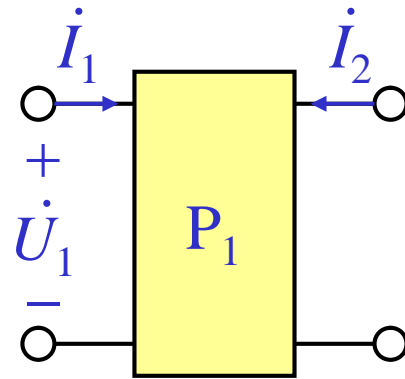

✓ ()
 ✓ $P_1(1)$
 ✓ $P_2(1)$
 ✓)

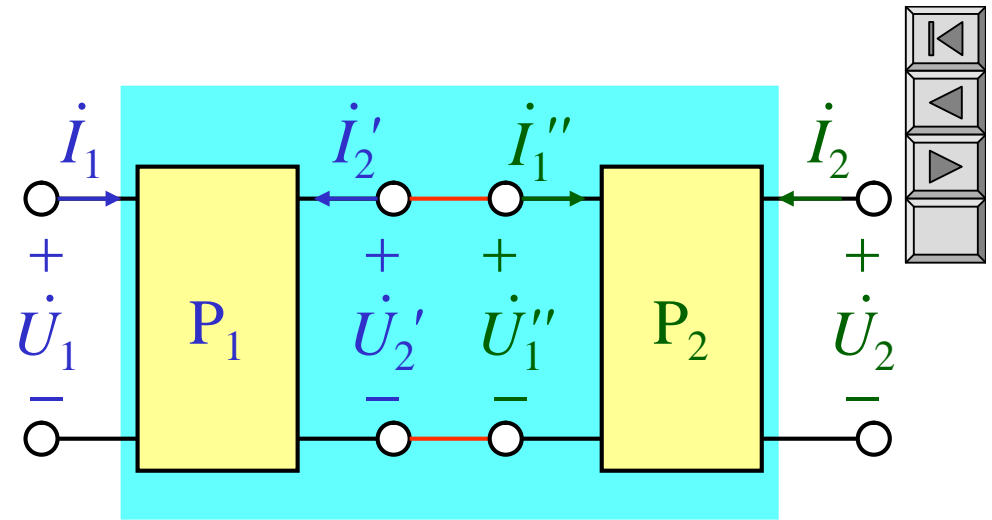

$$\dot{U}_2' = \dot{U}_1'' \quad \dot{I}_2' = -\dot{I}_1''$$

: $P_1 \quad P_2 \quad T$

$$T' = \begin{bmatrix} A' & B' \\ C' & D' \end{bmatrix} \quad T'' = \begin{bmatrix} A'' & B'' \\ C'' & D'' \end{bmatrix}$$

$$\begin{bmatrix} \dot{U}_1 \\ \dot{I}_1 \end{bmatrix} = T' \begin{bmatrix} \dot{U}_2' \\ -\dot{I}_2' \end{bmatrix} = T' \begin{bmatrix} \dot{U}_1'' \\ \dot{I}_1'' \end{bmatrix} = T' T'' \begin{bmatrix} \dot{U}_2 \\ -\dot{I}_2 \end{bmatrix} = T \begin{bmatrix} \dot{U}_2 \\ -\dot{I}_2 \end{bmatrix}$$

T

$$T = T' T''$$

$$T = T' T'' = \begin{bmatrix} \underline{A'} & \underline{B'} \\ \underline{C'} & \underline{D'} \end{bmatrix} \begin{bmatrix} A'' & B'' \\ C'' & D'' \end{bmatrix}$$

$$= \begin{bmatrix} A'A'' + B'C'' & A'B'' + B'D'' \\ C'A'' + D'C'' & C'B'' + D'D'' \end{bmatrix}$$

T

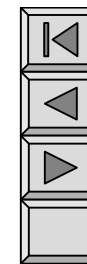

P389

16-12

(a) T

$$A' = 1 \quad C' = Y$$

$$D' = A' = 1 \quad B' = 0$$

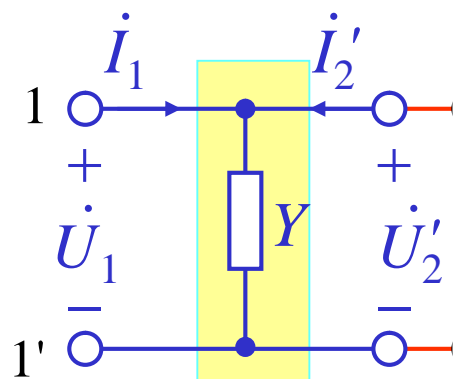

$$T = \begin{bmatrix} 1 & 0 \\ Y & 1 \end{bmatrix} \begin{bmatrix} A & B \\ C & D \end{bmatrix}$$

T

P_1

$$T_1 = \begin{bmatrix} A & B \\ C & D \end{bmatrix}$$

$$= \begin{bmatrix} A & B \\ AY + C & BY + D \end{bmatrix}$$

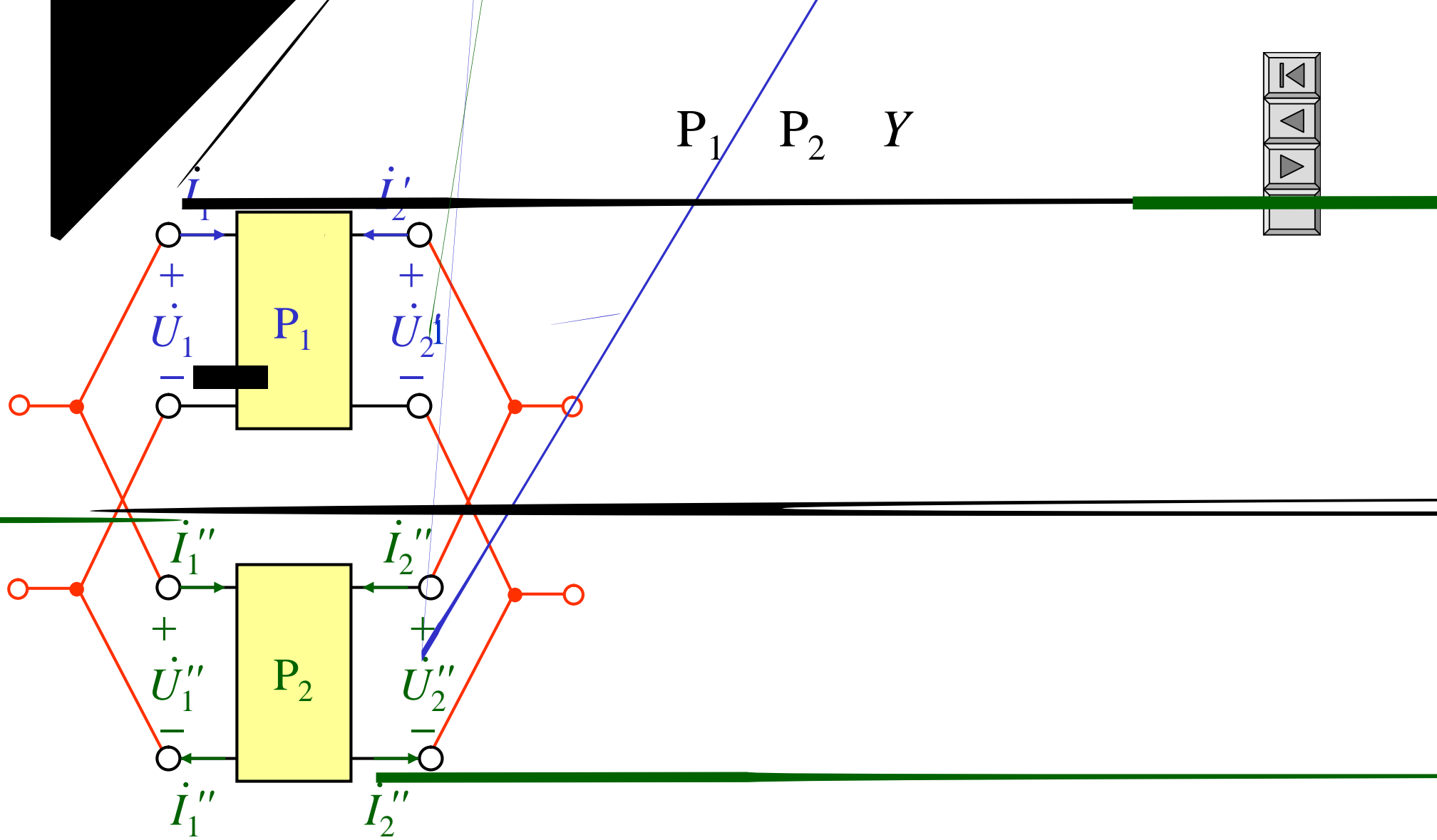

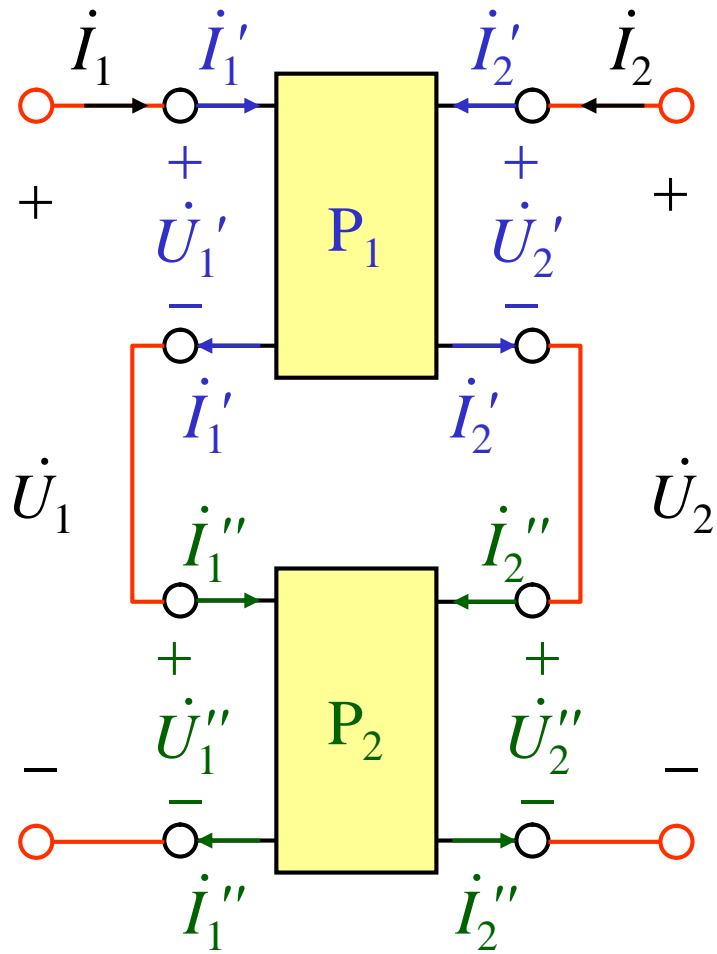

$$\dot{I}_1 = \dot{I}'_1 = \dot{I}''_1 \quad \dot{I}_2 = \dot{I}'_2 = \dot{I}''_2$$

$$\dot{U}_1 = \dot{U}'_1 + \dot{U}''_1 \quad \dot{U}_2 = \dot{U}'_2 + \dot{U}''_2$$

$$P_1 \quad P_2 \quad Z$$

$$Z' = \begin{bmatrix} Z'_{11} & Z'_{12} \\ Z'_{21} & Z'_{22} \end{bmatrix} \quad Z'' = \begin{bmatrix} Z''_{11} & Z''_{12} \\ Z''_{21} & Z''_{22} \end{bmatrix}$$

$$Z = Z' + Z''$$

§ 16-6

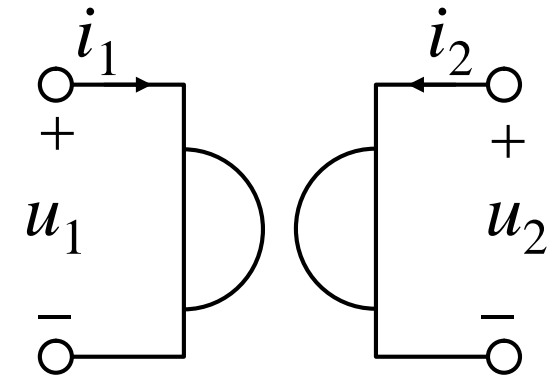
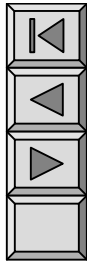

✓ VCR $\left. \begin{aligned} u_1 &= -r i_2 \\ u_2 &= r i_1 \end{aligned} \right\}$

$\left. \begin{aligned} i_1 &= g u_2 \\ i_2 &= -g u_1 \end{aligned} \right\}$

✓ $r \quad g$

$u_1 i_1 + u_2 i_2 = 0$

✓ () “ ”
 ()

$$\underline{\underline{L = r^2 C = C / g}}$$

$$I_2(s) = -sC U_2(s)$$

VCR

$$U_1(s) = -r I_2(s)$$

$$U_2(s) = r I_1(s)$$

$$U_1(s) = r sC U_2(s)$$

$$= r^2 sC I_1(s)$$

$$Z_{in} = \frac{U_1(s)}{I_1(s)} = s r^2 C = s L$$

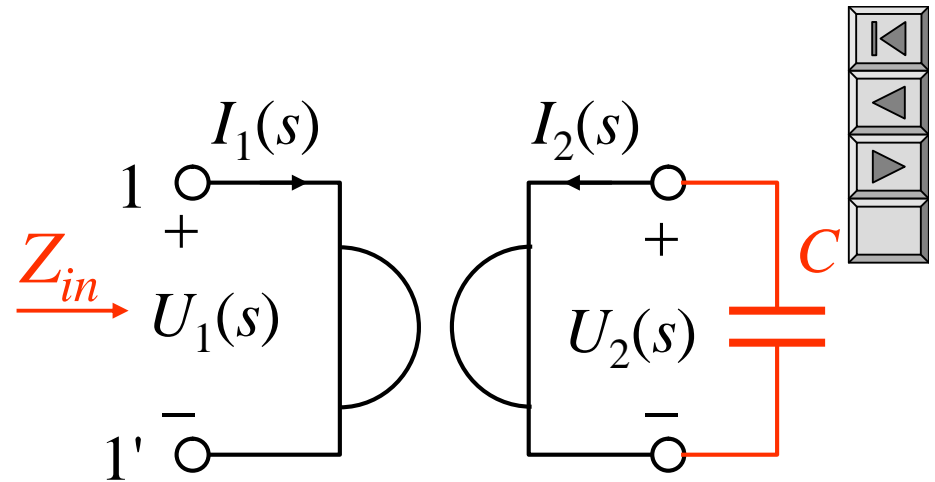

$$C = 1\mu \quad r = 50k$$

$$L = 50,000^2 \times 10^{-6} = 2500H$$

$$\mathbf{Z} \quad \mathbf{Z} = \begin{bmatrix} 0 & -r \\ r & 0 \end{bmatrix}$$

$$\mathbf{Y} \quad \mathbf{Y} = \begin{bmatrix} 0 & g \\ -g & 0 \end{bmatrix}$$

(NIC)

NIC

1. T VCR

(1)

$$\begin{bmatrix} U_1(s) \\ I_1(s) \end{bmatrix} = \begin{bmatrix} 1 & 0 \\ 0 & -k \end{bmatrix} \begin{bmatrix} U_2(s) \\ -I_2(s) \end{bmatrix}$$

(2)

$$\begin{bmatrix} U_1(s) \\ I_1(s) \end{bmatrix} = \begin{bmatrix} -k & 0 \\ 0 & 1 \end{bmatrix} \begin{bmatrix} U_2(s) \\ -I_2(s) \end{bmatrix}$$

$$I_1(s) = -I_2(s),$$

$$U_1(s) = -kU_2(s),$$

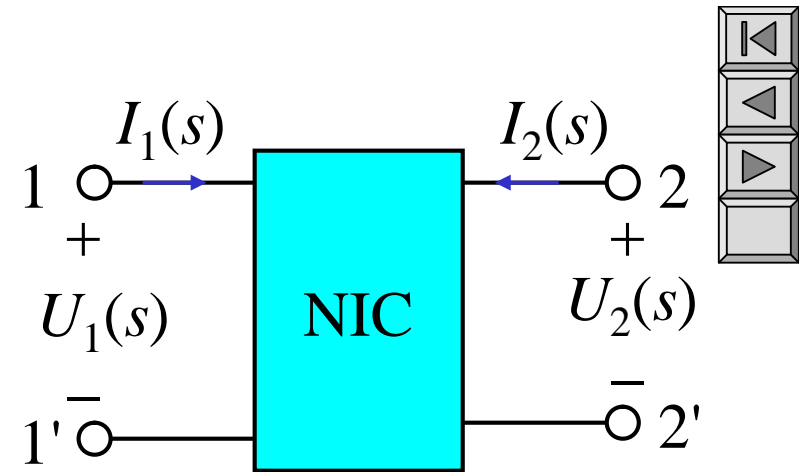

$$U_1(s) = U_2(s),$$

$$I_1(s) = kI_2(s),$$

2. NIC

$$U_1(s) = U_2(s)$$

$$I_1(s) = kI_2(s)$$

$$Z_1(s) = \frac{U_1(s)}{I_1(s)} = \frac{U_2(s)}{kI_2(s)}$$

$$U_2(s) = -Z_2(s)I_2(s)$$

$$Z_1(s) = -\frac{Z_2(s)}{k}$$

